

Section A-A
S= 1:100

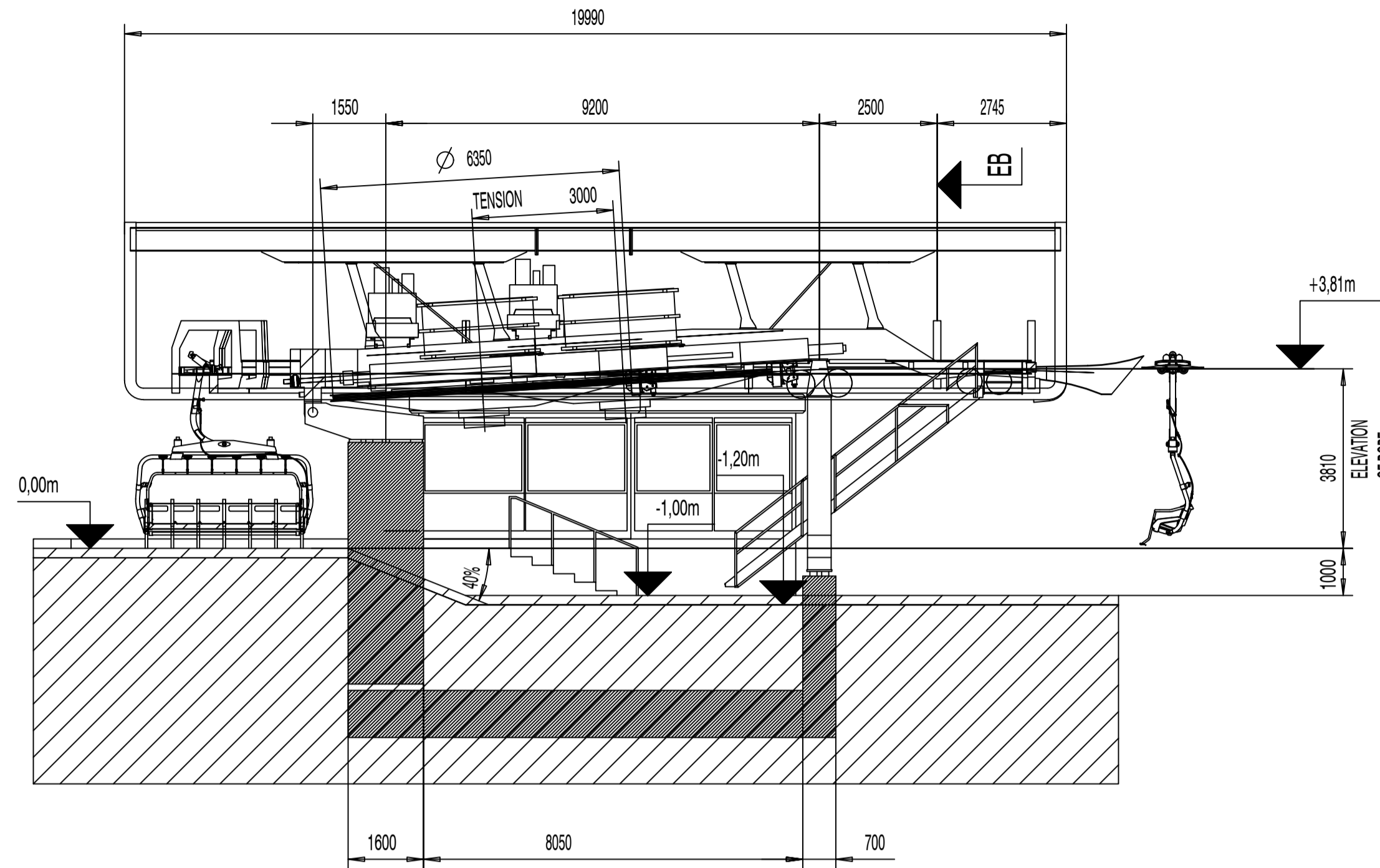

VIEW C

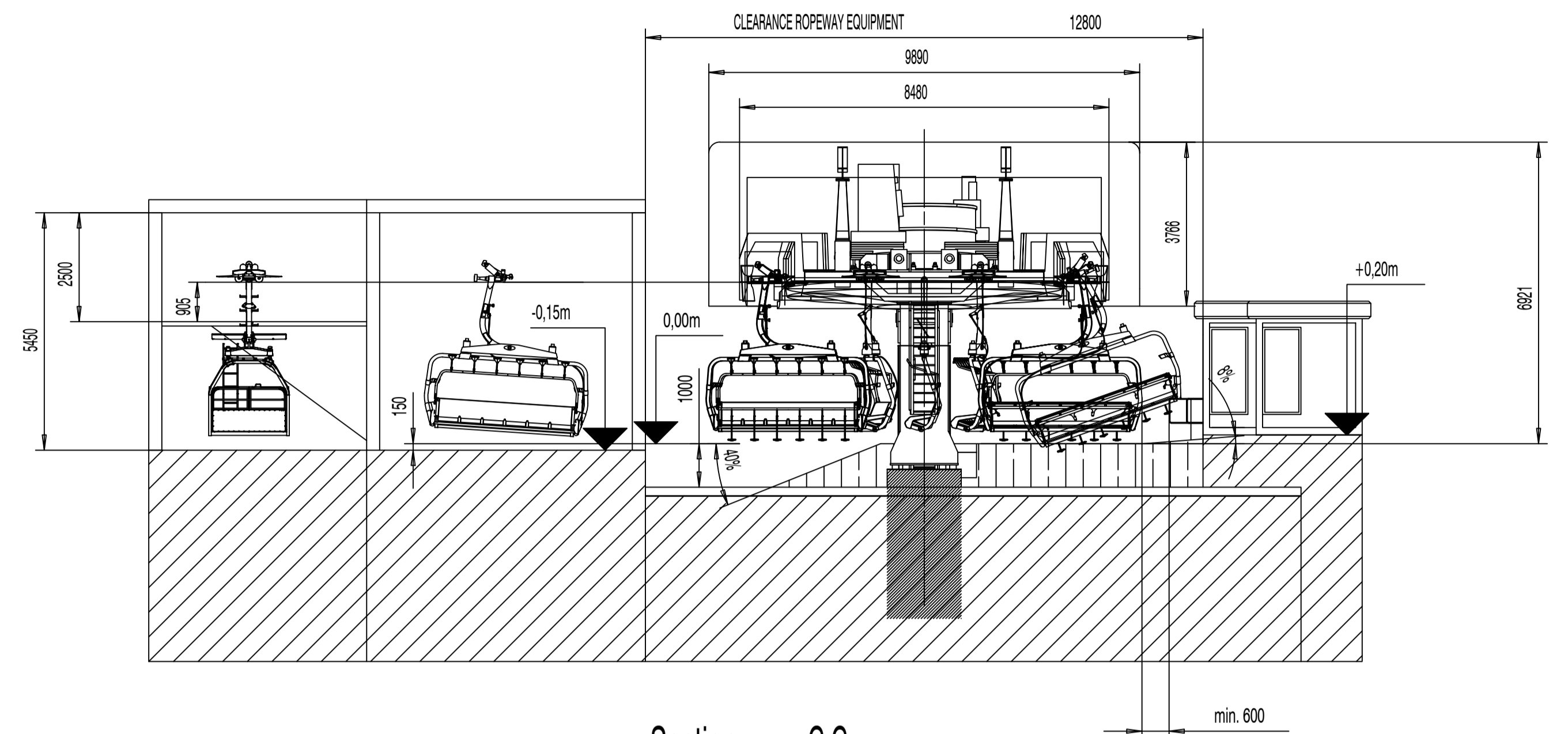

Section C-C
M= 1:100

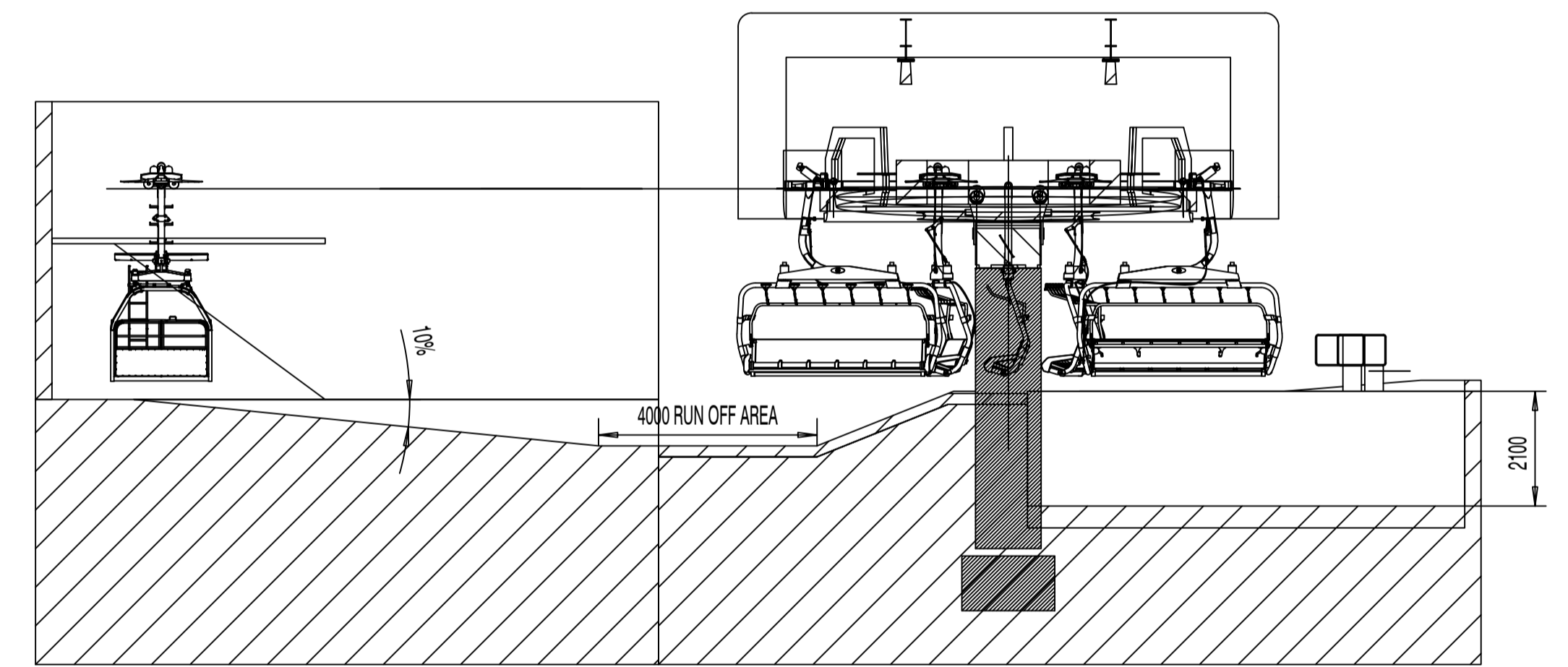

Loading situation
M= 1:200

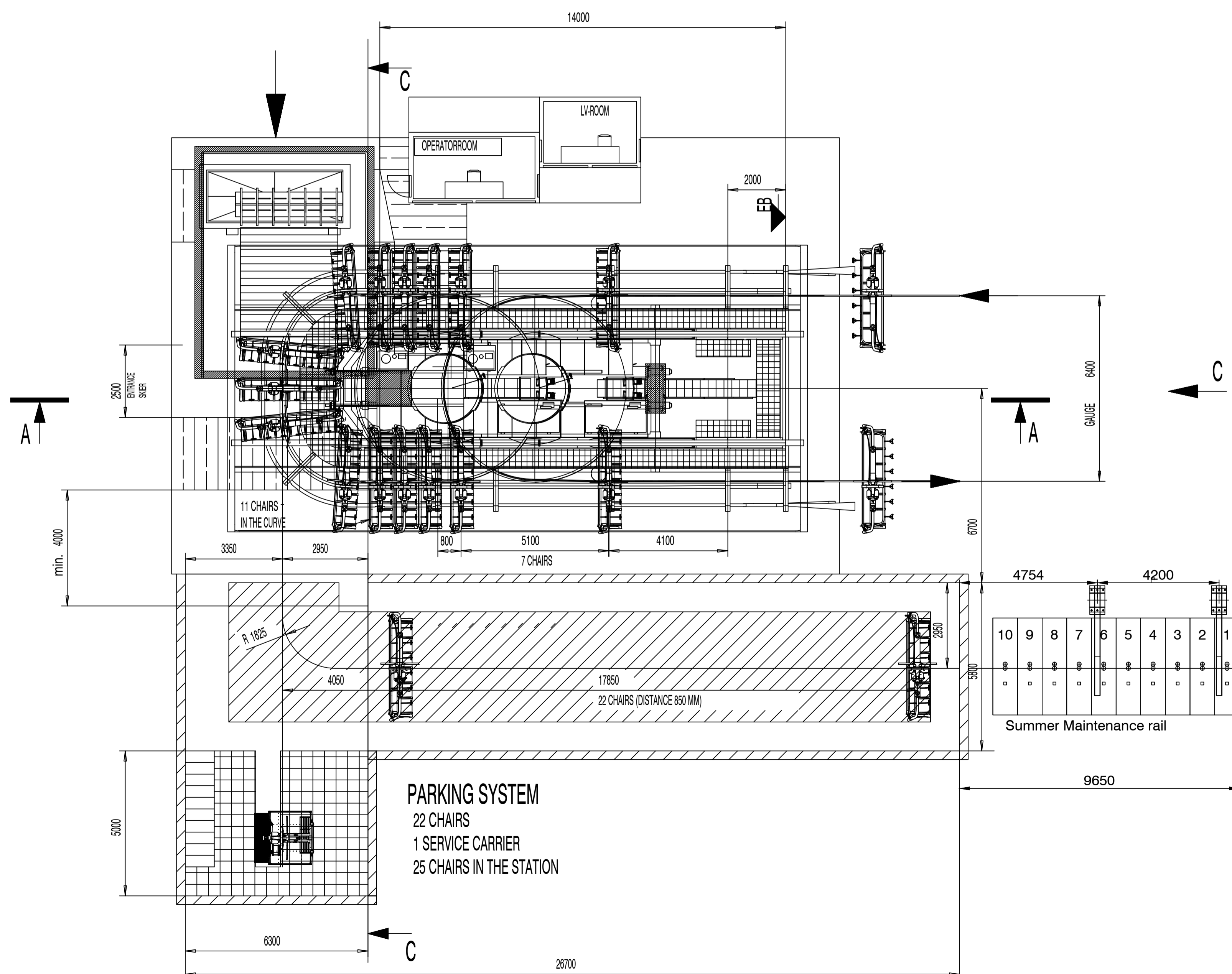
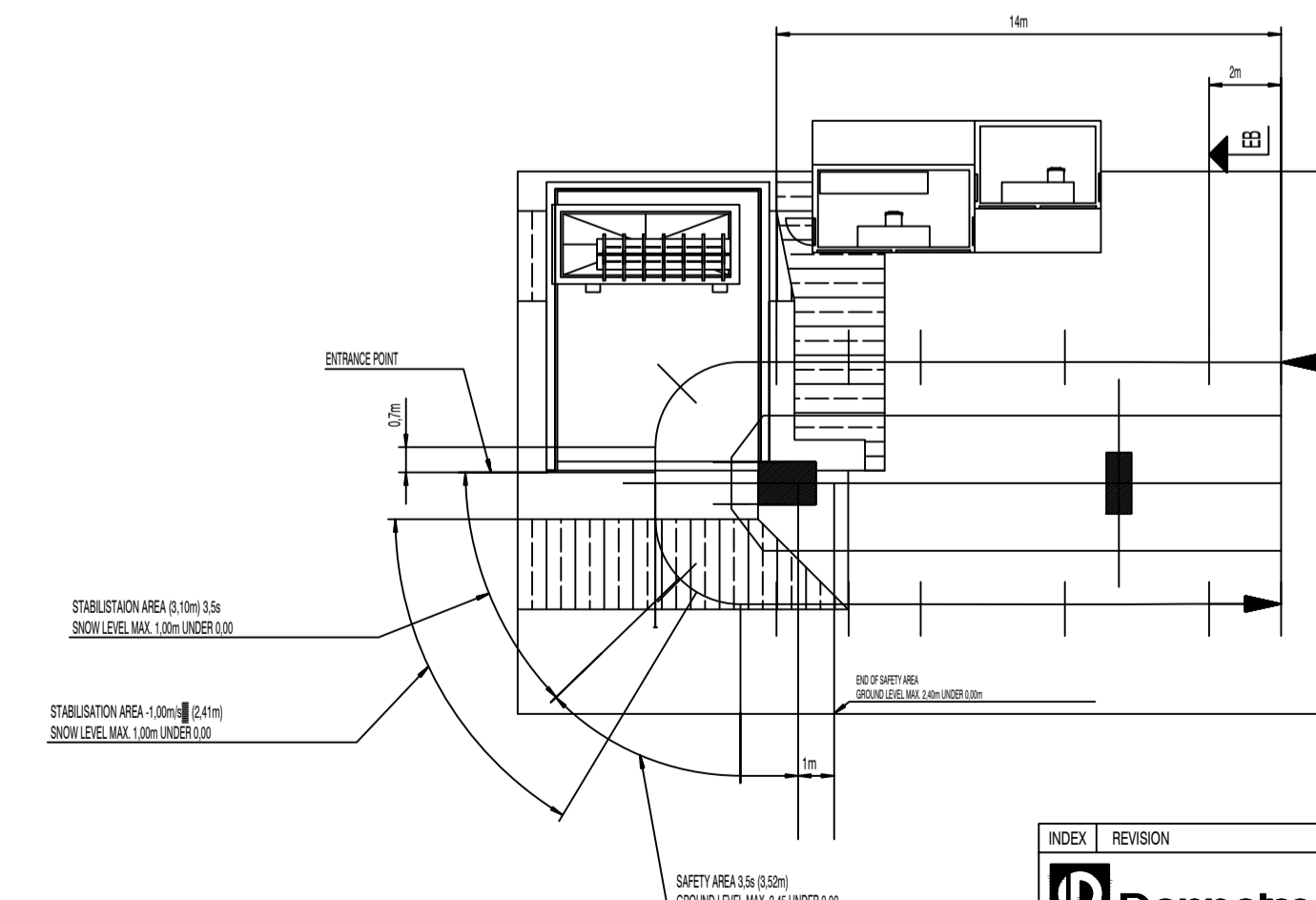

Standard		
safety area	EN12929-1:2015,	11.2
stabilisation area	EN12929-1:2015,	11.2
approach area	EN12929-1:2015,	11.3

Performance data	
Capacity	2400 pph
Interval	9.0 s
Speed	5.0 m/s
Rope diameter	43 mm
Cycle time	24.5 s
Loading speed	0.80 m/s
Rope tension ΣmaxR	- kN
Rope tension Σ Smax	- kN

11960596

INDEX	REVISION	DATE	NAME	COMPLIANT	ID NO.
	0				

SCALE	DATE	NAME
1/100	25.05.2022	HGA

SCALE	DATE	NAME
0 kg		

ORIGINAL DRAWING NO.	ID NO.
20249325E309001	11958816

DRAWING NO.	INDEX
20249671E309001 ¹	NZ-b

IMPORTANT:
PRELIMINARY DRAWING
DETAIL PLANNING
ONLY UPON CONSULTATION
AND APPROVAL OF ENGINEERING DEPT.

THIS DRAWING IS INTELLECTUAL PROPERTY OF DOPPELMAYR SELBENEN GMBH AND IS TRANSFERRED TO INNOVA PATENT GMBH AS OF DEC 31ST OF THE YEAR OF MAKING AND MUST NOT BE COPIED NOR UTILIZED IN WHOLE OR IN PART WITHOUT PERMISSION AND IS SUBJECT TO RETURN UPON REQUEST.

Section A-A
S= 1:100

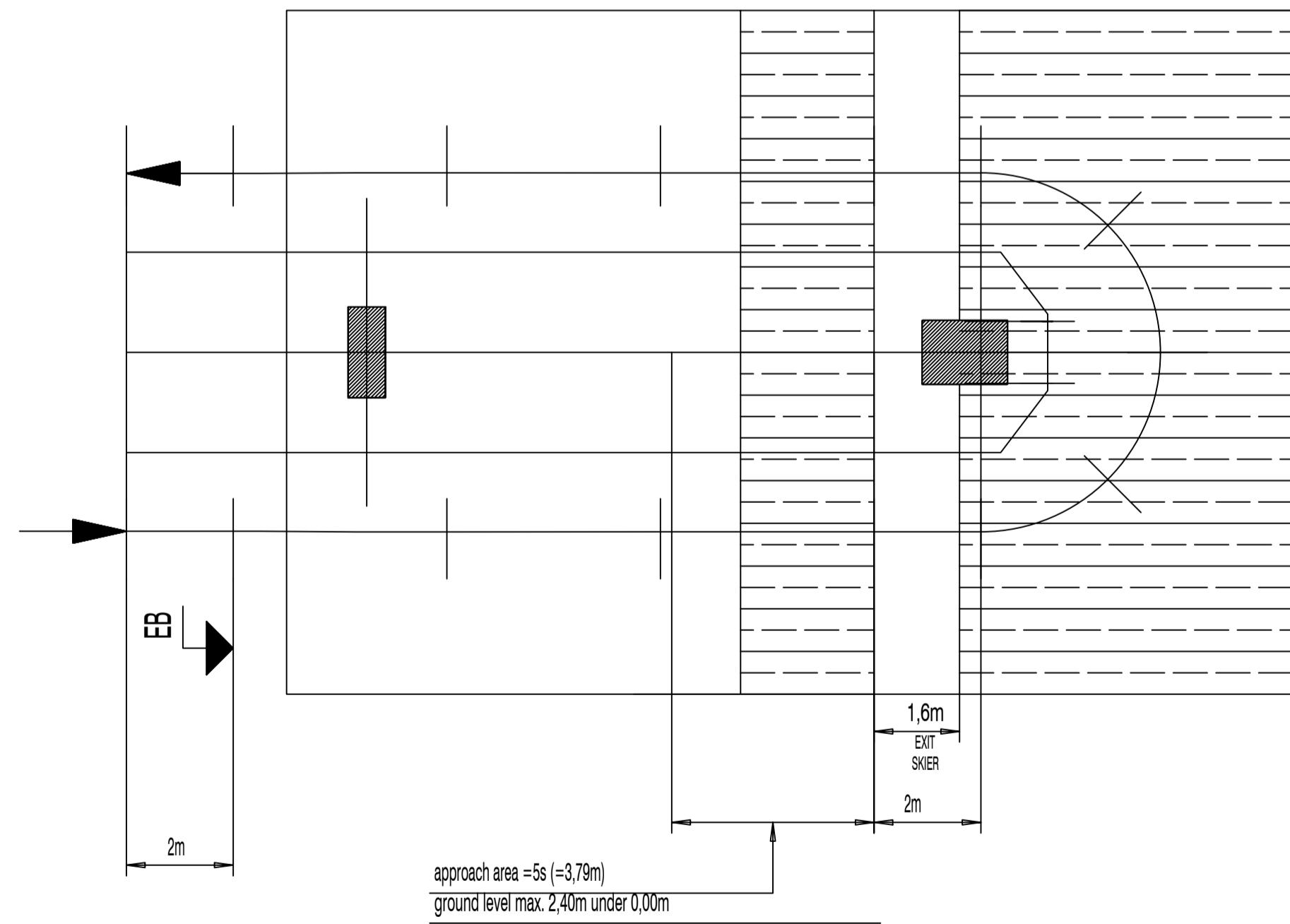
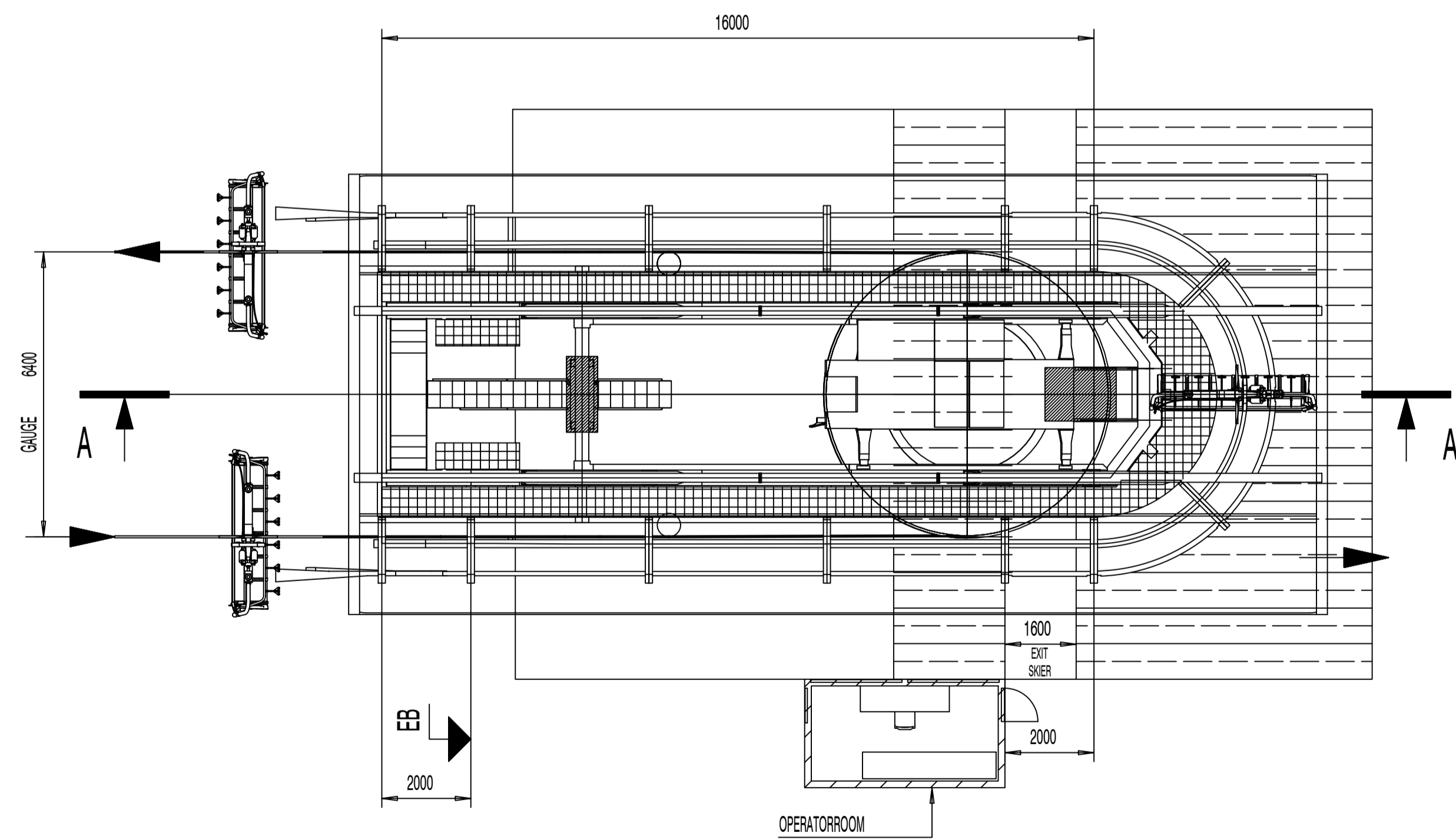
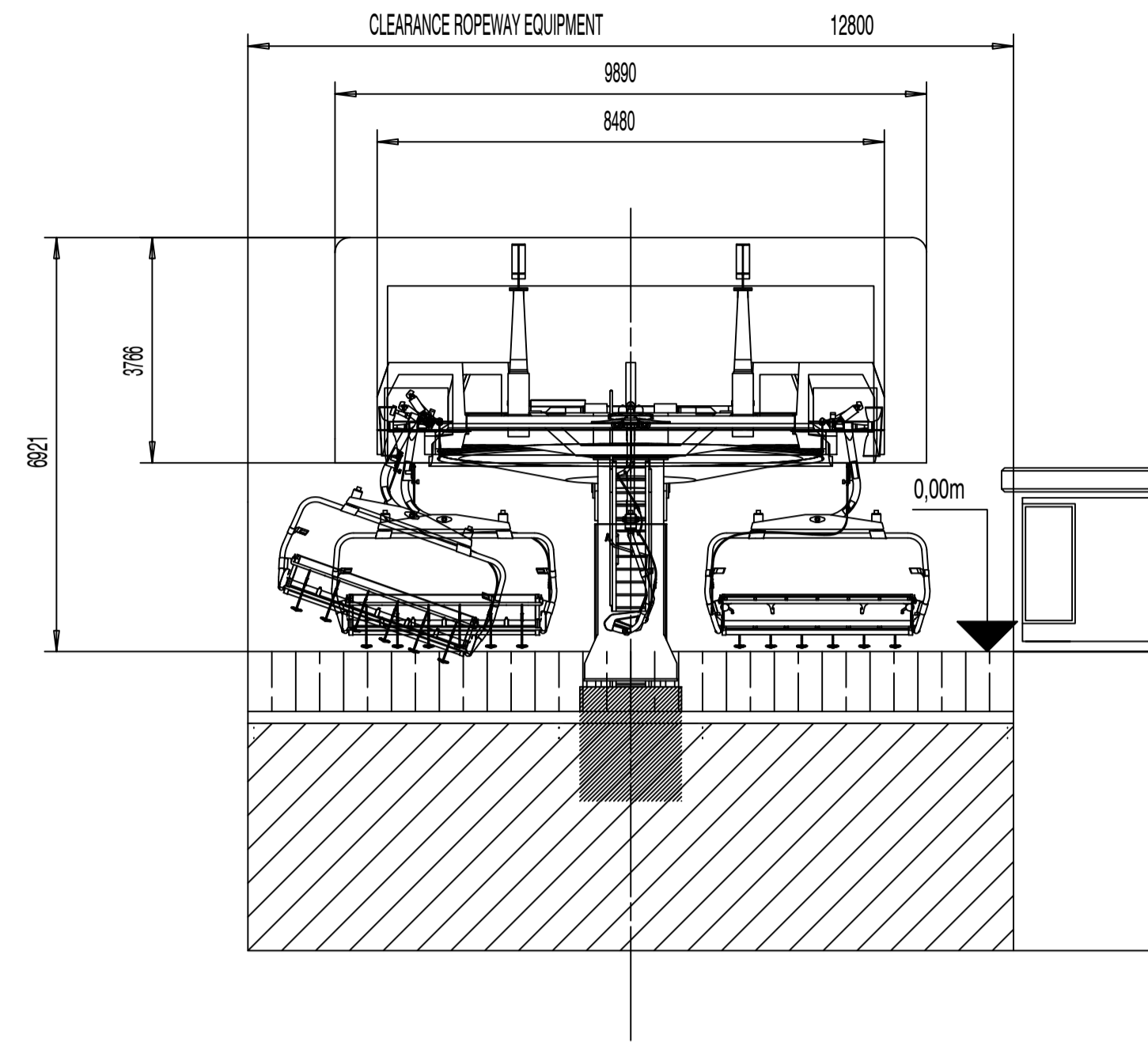
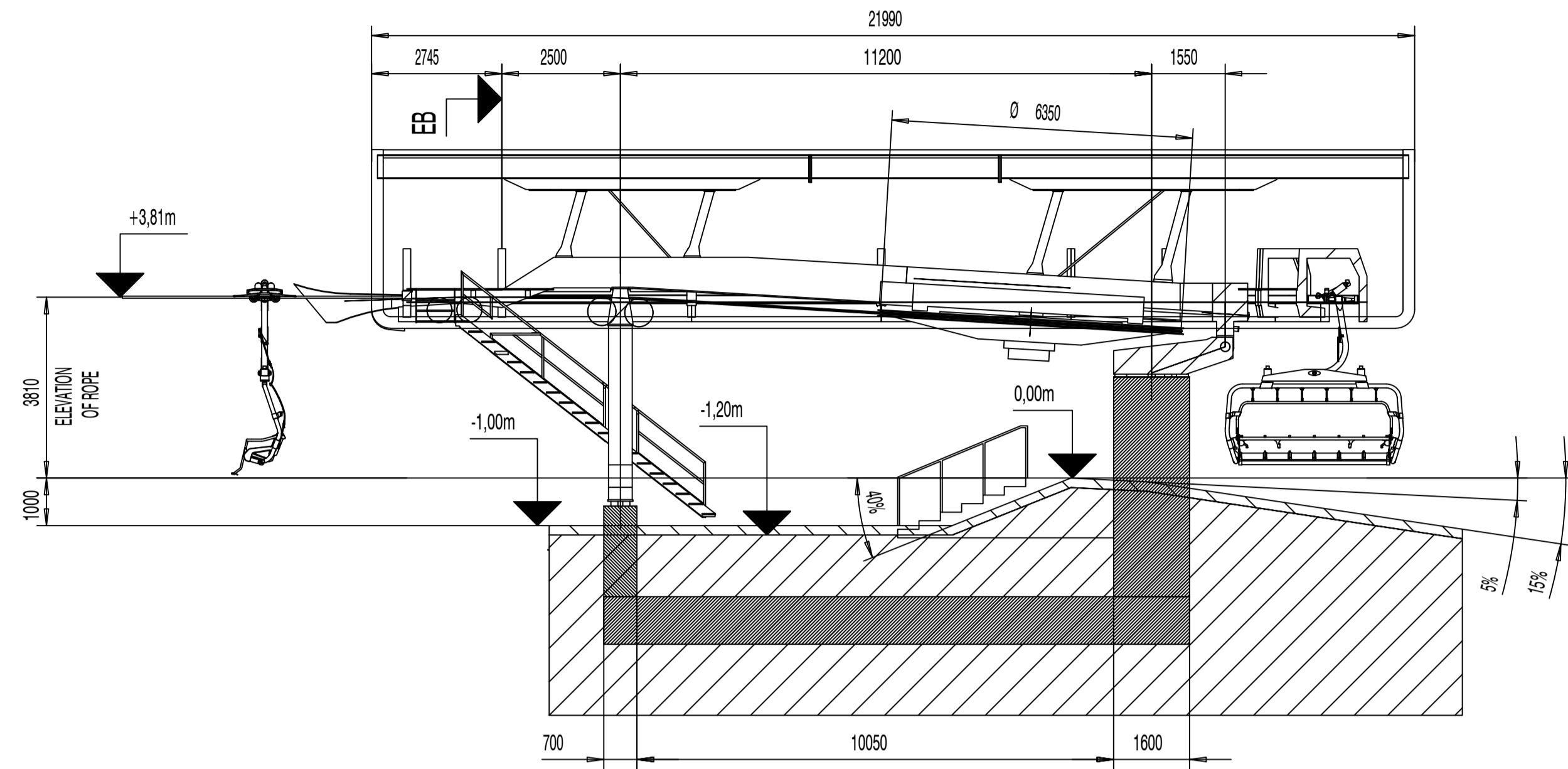

Standard		
safety area	EN12829-1:2015,	11.2
stabilisation area	EN12829-1:2015,	11.2
approach area	EN12829-1:2015,	11.3
Performance data		
Capacity		2.400 pph
Interval		9.0 s
Speed		5.0 m/s
Rope diameter		43 mm
Cycle time		29 s
Unloading speed		0,80 m/s
Rope tension S _{maxR}		- kN
Rope tension S _{max}		- kN
		11952615

IMPORTANT:
 PRELIMINARY DRAWING
 DETAIL PLANNING
 ONLY UPON CONSULTATION
 AND APPROVAL OF ENGINEERING DEPT.

INDEX	REVISION	DATE	NAME	Q-CLASS	CONFIGURATION	SCALE	DATE	NAME
						1/100	25.05.2022	HGA
		INNOVA PATENT GMBH Konrad-Doppelmayr-Strasse 1 A-8222 WOLFRATSHAUSEN		0		FACTOR: W.X.Y.Z		
INSTALLATION	SHADOW BASIN					0 kg	Issued for Consenting	
ORDER	WAA0001632							
TOP RETURN FIXED		DCD6-L / D16-6.4						
ORIGINAL DRAWING NO.		20247033E309001		ID NO.		11946418		
DRAWING NO.		20248347E309001		INDEX		NZ-b		

THIS DRAWING IS INTELLECTUAL PROPERTY OF DOPPELMAYR SELBANHVEN GMBH AND IS TRANSFERRED TO INNOVA PATENT GMBH AS OF DEC 31ST OF THE YEAR OF MAKING AND MUST NOT BE COPIED NOR UTILIZED IN WHOLE OR IN PART WITHOUT PERMISSION AND IS SUBJECT TO RETURN UPON REQUEST.

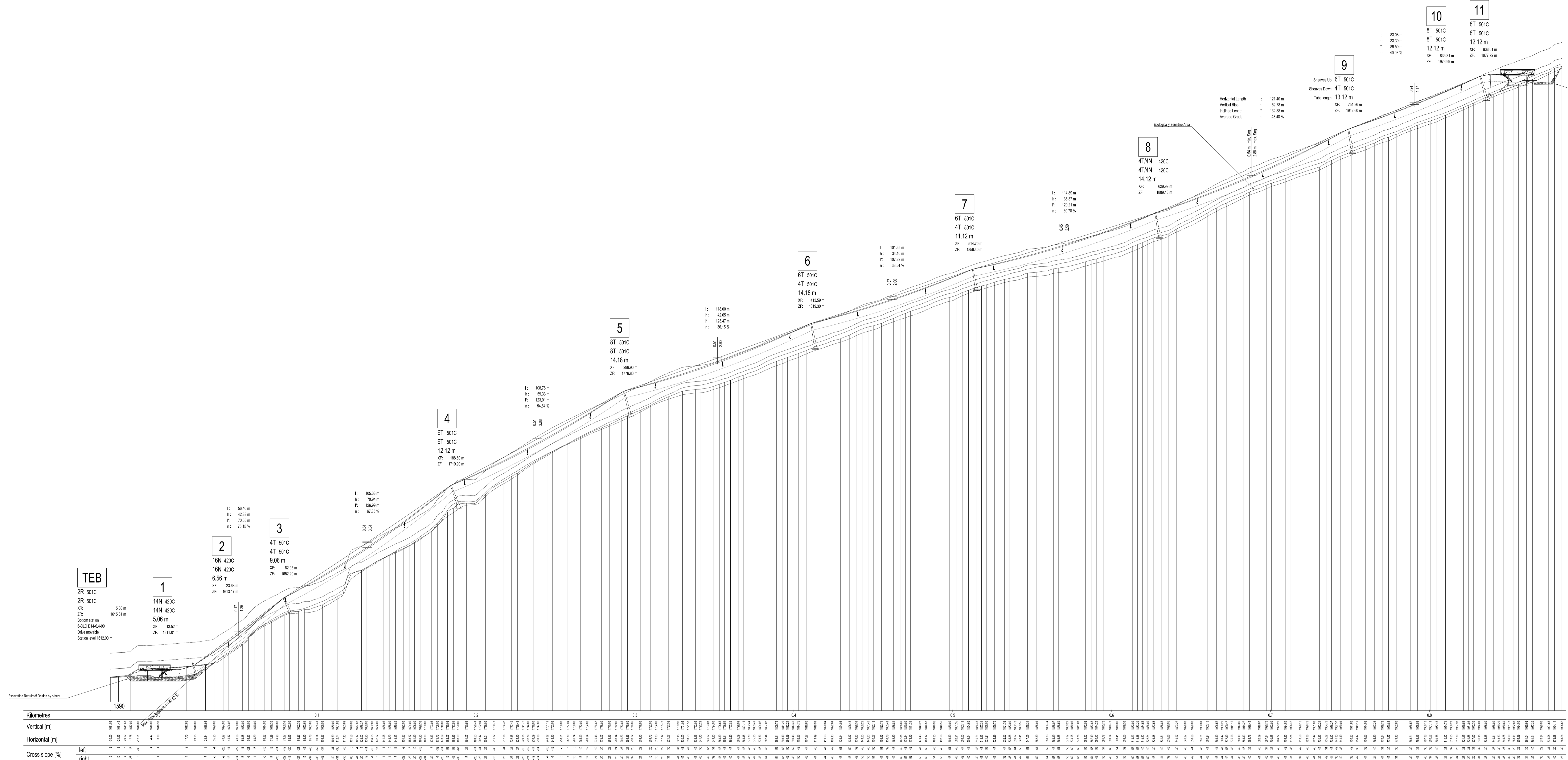

10
8T 501C
8T 501C
12.12 m
XF: 835.31 m
ZF: 1976.69 m

11
8T 501C
8T 501C
12.12 m
XF: 838.01 m
ZF: 1977.72 m

BEB
2R 501C
2R 501C
1960.51 m
XF: 847.29 m
ZF: 1990.51 m
Top station: 194022.016-6.4
Return Road
Station level: 1960.29 m

9
Sheaves Up: 6T 501C
Sheaves Down: 4T 501C
Tube length: 13.12 m
XF: 830.00 m
ZF: 1942.60 m

Horizontal Length	1: 121.40 m
Vertical Rise	h: 52.78 m
Inclined Length	l: 132.38 m
Average Grade	n: 43.48 %

8
4T/4N 420C
4T/4N 420C
14.12 m
XF: 820.00 m
ZF: 1989.16 m

7
6T 501C
4T 501C
11.12 m
XF: 814.70 m
ZF: 1956.40 m

6
6T 501C
4T 501C
14.18 m
XF: 813.59 m
ZF: 1919.30 m

5
8T 501C
8T 501C
14.18 m
XF: 806.50 m
ZF: 1779.80 m

4
6T 501C
6T 501C
12.12 m
XF: 800.00 m
ZF: 1719.90 m

2
16N 420C
16N 420C
6.56 m
XF: 783.63 m
ZF: 1613.17 m

1
14N 420C
14N 420C
5.00 m
XF: 781.81 m
ZF: 1611.81 m

TEB
2R 501C
2R 501C
5.00 m
XF: 1615.81 m
ZF: 1615.81 m
Bottom station: F-CLD 014-6-4-0
Difference: 1912.00 m

Kilometres	0.00	0.05	0.10	0.15	0.20	0.25	0.30	0.35	0.40	0.45	0.50	0.55	0.60	0.65	0.70	0.75	0.80	0.85	0.90	0.95	1.00	
Vertical [m]	1615.81	1615.81	1615.81	1615.81	1615.81	1615.81	1615.81	1615.81	1615.81	1615.81	1615.81	1615.81	1615.81	1615.81	1615.81	1615.81	1615.81	1615.81	1615.81	1615.81	1615.81	1615.81
Horizontal [m]	0.00	0.00	0.00	0.00	0.00	0.00	0.00	0.00	0.00	0.00	0.00	0.00	0.00	0.00	0.00	0.00	0.00	0.00	0.00	0.00	0.00	
Cross slope [%]	left	right	left	right	left	right	left	right	left	right	left	right	left	right	left	right	left	right	left	right	left	right

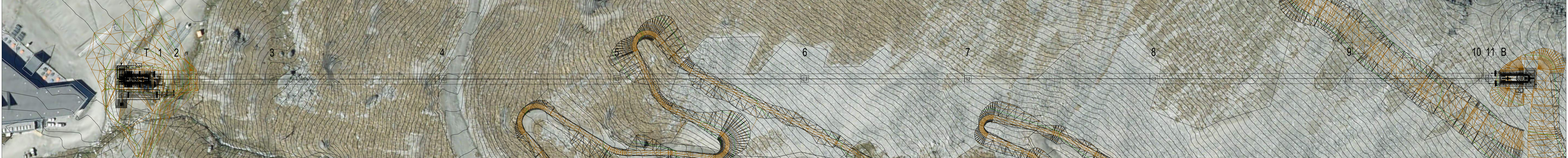

Profile origin:
 Profile file: Shadow_Basin_20220111 (ID 19213).gel
 Ropeway file: WAA0001632_Shadow_Basin_6-CLD_REV_H_010422_FN (ID 20386).dtd
 Program: Seiba 1.68.3 CIN:164878654
 WAA0001632_Shadow_Basin_6-CLD_Rev-H_2022-04-05 20:40 3

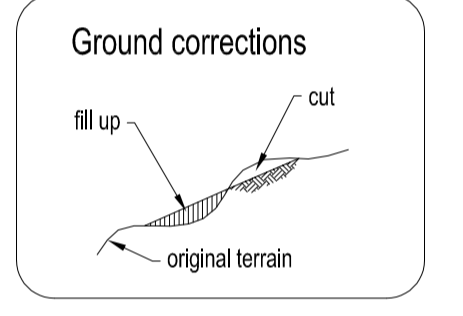

Profile 6-CLD Shadow Basin

Customer: The Remarkables
 Location: Queenstown, New Zealand

Uphill Side	Right	Ø Haul Rope	43 mm
Drive Station	Bottom	Ø Drive Bullwheel	6.35 m
Tension Station	Bottom	Ø Return Bullwheel	6.35 m
Return Station	Top	Rope Gauge on Line	6.40 m
Horizontal Length	842.29 m	Drive Output Continuous	361 kW
Vertical Rise	374.70 m	Drive Output Starting	435 kW
Average Grade	44.49 %	Drive Output Braking	-317 kW
Max. Rope Inclination	87.52 %	Elevation of Drive Station	1616 m
Inclined Length	929.50 m	Uphill Transportation	100 %
Spliced Rope Length	1920.60 m	Downhill Transportation	50 %

Drive Speed	Initial	Final
Capacity	m/s	5.00 m/s
Number of Carriers	pph	2400 pph
Carrier Spacing	m	47
Carrier Interval	s	45.06 m
Trip Time	min	9.01 s
		3.53 min

H	Top Station, Bottom station and Towers 10 & 11 updated	2022-04-01	FN
D	Top station moved, New GEL, Towers 5-11 moved and changed	2022-01-13	HGA
C	Station lengths adjusted, T9 16m height	2021-12-10	FN
B	Moved Top station -14.30m and added tower 11	2021-09-30	HGA
A	Move bottom Station +5m into hillside	2021-09-26	NACL

Project No.	WAA0001632	Drawn	2021-09-28	Scale	NACL	1:1000	Drawing No.	20009735P500100 H
-------------	------------	-------	------------	-------	------	--------	-------------	-------------------

This drawing is the intellectual property of Doppelmayr and it must not be copied, nor utilized in whole or in part without permission and is subject to return upon request.

Issued for Consenting