

Development of underwater line setters for bottom longlines

BCBC2018-01

Final Report

Prepared for the Department of Conservation by Vita Maris

D. Goad, D. Kellian, B. Kiddie

May 2020



Abstract

Two similar designs for setting manually baited bottom longlines underwater were developed and improved over the course of 13 trips to sea on three snapper longline vessels.

Both designs employed a similar concept with a towed wheel or guide used to force the mainline to a depth of 7 – 10 m, approximately 20 m behind the vessel. The setters were held at depth using a lead weight, and a hinged arm and paravane were used to provide stability and to separate the tow cable from the longline.

Matching snood clip and wheel design so that hooks were guided beside the wheel showed promise, though further work is needed to achieve this consistently and to reliably deploy floats and weights.

The setter with a guide was improved iteratively and sanma and squid baits were successfully deployed at depth. Pilchard baits were more fragile and loss rates, even before entering the setter, were unacceptably high.

Initially, gear was deployed at high mainline tension as this provided better angles of attack for the mainline entering the setter, greater mainline retention, and deeper deployment depths at speed. However, setting baits at depth with high mainline tension returned lower catch rates and higher bait return rates than gear set normally, with minimal mainline tension. Deploying gear through the setter with a guide at low mainline tension improved catch rates but produced more curvature in the mainline between the vessel and the setter, which required some trade off in speed and achievable depth.

Further work is necessary to accurately measure and control mainline tension, and to investigate optimal setter configuration to maximise deployment depth, setting speed, and catch rates at low mainline tension.

Underwater setting has the potential to allow fishers to reduce risk to birds and meet government mitigation standards by settings lines below 10 m depth within 50 m of the stern of the vessel, without substantially altering fishing operations.

Introduction

Estimated capture rates of at-risk seabirds by the bottom longline fleet are likely to be unsustainable long term; both scientifically (Webber, 2020), and from a social 'licence to operate' perspective (e.g. RNZ, 2020), indicating the need for improvements in performance over and above that achievable using traditional mitigation measures.

The Agreement for the Conservation of Albatrosses and Petrels (ACAP) best practice guidance for bottom longline fishing includes use of the following three measures at all times: night setting, line weighting, and tori lines (ACAP, 2019). New Zealand regulations require a tori line and either night setting or line weighting (MPI 2008). Setting lines for the 'bite time' over the change of light means many sets targeting snapper in the summer months do not meet the ACAP definition of best practice, or fall under night setting as defined by the New Zealand regulations (MPI, 2018, Pierre et al., 2013). Additionally, the ACAP advice recognises that night setting may not be effective in bright moonlight, or for crepuscular/nocturnal foragers, and notes that mitigation measures need to be acceptable to fishers and not affect fish catch rates. Similarly, tori lines are often not fully effective to the prescribed aerial extent, and use is not consistent across the fleet (pers. obs. DG).

Draft Mitigation Standards to Reduce the Incidental Captures of Seabirds in New Zealand Commercial Fisheries (FNZ, 2019), which are intended to be implemented through the National Plan of Action Seabirds 2020, require that hooks set during 'high risk periods' should sink to 10 m depth by the end of the aerial portion of the tori line. This would require long tori lines and/or conservative line weighting regimes and/or slow setting speeds, none of which are commonly used in the fishery at present, or legally required (MPI, 2018).

Consequently, fishing operations are often constrained, with reduced efficiency, as fishers avoid areas and times when birds are foraging, and selectively increase line weighting to increase sink rate and reduce the risk of capture. Such ad-hoc approaches have been a part of skippers' fishing strategies for many years and have become more widespread in response to increased attention and awareness (Goad et al., 2010, Pierre, 2018).

Underwater setting would increase sink rates, reduce risk to birds, and add an extra level of flexibility for fishers. It is particularly relevant for high risk times and/or areas, when fishers at present have to stop fishing to reduce risk to birds. Additionally, it could provide fishers with an option for meeting the Mitigation Standards without substantially altering fishing operations.

Efforts to reduce the availability of pelagic longline hooks to birds has focused on increasing the sink rate of the hook, either mechanically (Gilman et al., 2003, Ryan and Watkins 2002, Robertson and Ashworth 2010), or by adding weight (e.g. Robertson 2013), or protecting the barb of the hook (Oceansmart, 2011, Hookpod, 2020). These 'hook by hook' approaches are feasible for pelagic longlines where branch lines are longer than 10 m, baited as they are set, set relatively slowly (e.g. Robertson 2013, Goad et al., 2019), and the hook sinks, certainly initially, independently from the mainline (Robertson et al., 2010).

Conversely, the inshore manual baiting demersal longline fleet in New Zealand clip on pre-baited hooks with short branchlines (or snoods), typically 0.6 m length, to a stoppered mainline relatively quickly (Goad et al., 2010). Therefore, in order to set bottom longlines underwater, both the hook and the mainline have to be deployed at depth. This presents a different set of challenges, and a downward force must be applied to the mainline in order to achieve sufficient depth.

Objectives

The research described here continues work on a line setter with a wheel described in Goad (2011) and work on a similar design using a guide instead of the wheel developed and described in Baker et al. (2016). Research addressed the following objectives:

1. Develop and improve a towed underwater line setter using a guide to deploy the longline at depth.
2. Develop and improve a towed underwater line setter using wheels to deploy the longline at depth.
3. Assess the performance of both underwater setting devices during a series of sea trials.

Description of the concept

Both designs developed here are based on the same concept: A lead ball is towed behind the vessel at depth. Attached to the ball is a wheel or guide which is placed over the mainline, forcing the longline down to the depth of the ball. In order to separate the tow cable from the mainline, and to keep the device tracking in a straight line, the wheel or guide is attached behind the lead ball on a hinged arm. A paravane holds the arm horizontal behind the tow point and the lead ball is attached below the tow point to provide roll stability (Figure1).

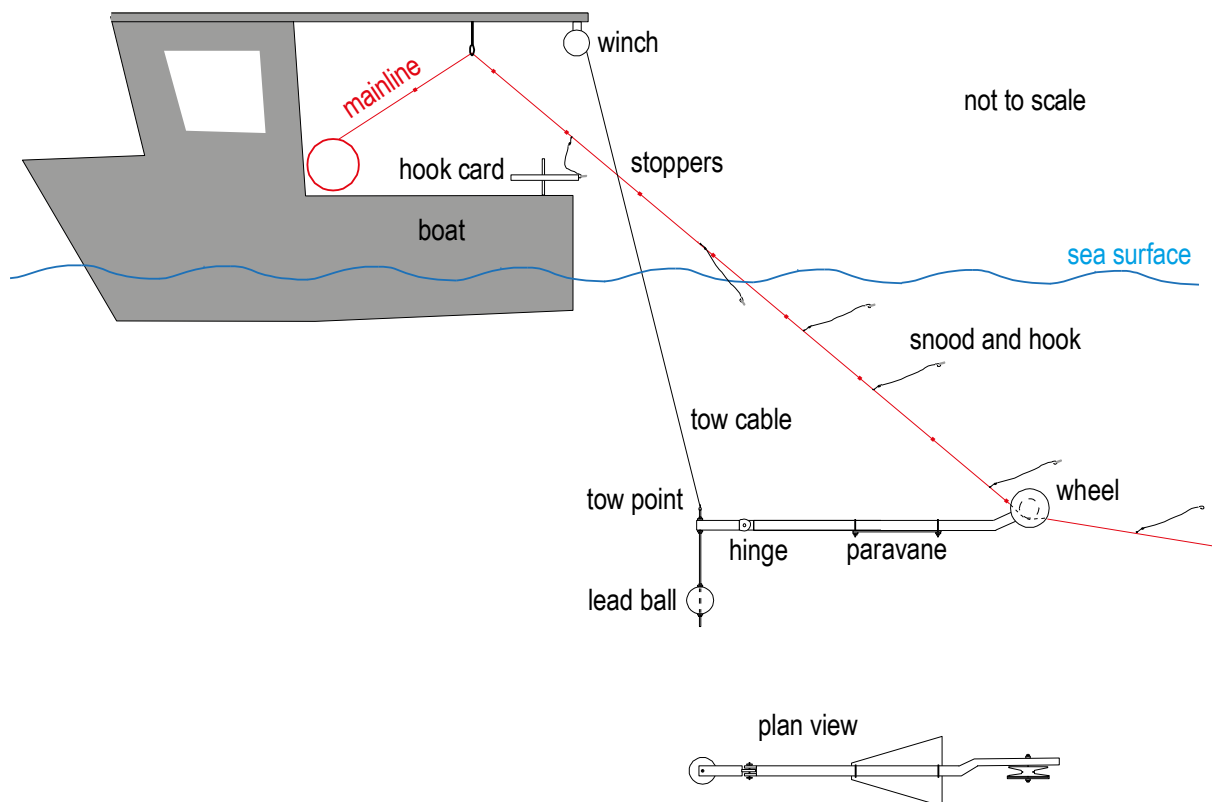

Figure 1. Schematic diagram of the line setter with wheels, modified from Goad (2011).

Overview of methods

In line with previous work, development of both designs was progressed by iterative improvement. A series of trips to sea were undertaken to test modifications. During test deployments data such as vessel speed, tow cable angle, and line tension were measured directly. GoPro cameras were attached to the setter to record the passage of hooks, and time depth recorders (TDRs) were attached to the line setter to produce a depth profile during deployment. For some sets TDRs were also deployed on the mainline. On recovery of the setter depth records from the TDRs were examined and video footage was watched at reduced speed, to identify areas for improvement.

Typically, modifications to the setter were made prior to the subsequent deployment and this cycle continued throughout the project. Where catch rates were of interest all fish caught on the longline were counted, grouped either by treatment or by section within treatment.

This process of iterative improvement on a deployment by deployment basis does not readily lend itself to reporting in the normal 'IMRAD' manner so the work has been split by device type and summarised in the body of the report. Trip by trip progress and detailed results and discussion are appended. Although this approach necessitates some repetition the appendices allow the reader to follow the work flow and understand why development progressed in the manner described.

At sea trials and development of setter with a wheel

This section summarises the outcomes from five trips to sea developing the setter with wheels, addressing the following specific objectives:

1. Refining the geometry of the setter to allow for the smooth passage hooks, baits, weights and floats
2. Matching wheel and clip design to ensure snoods are consistently turned outwards and pass beside the wheel
3. Sea trials to examine the passage of gear through the setter
4. Quantifying performance including sink rate, bait loss, hook loss, depth achieved, and distance behind the vessel

Description of device

The starting point for development work was a modified version of the design shown in Figure 1.

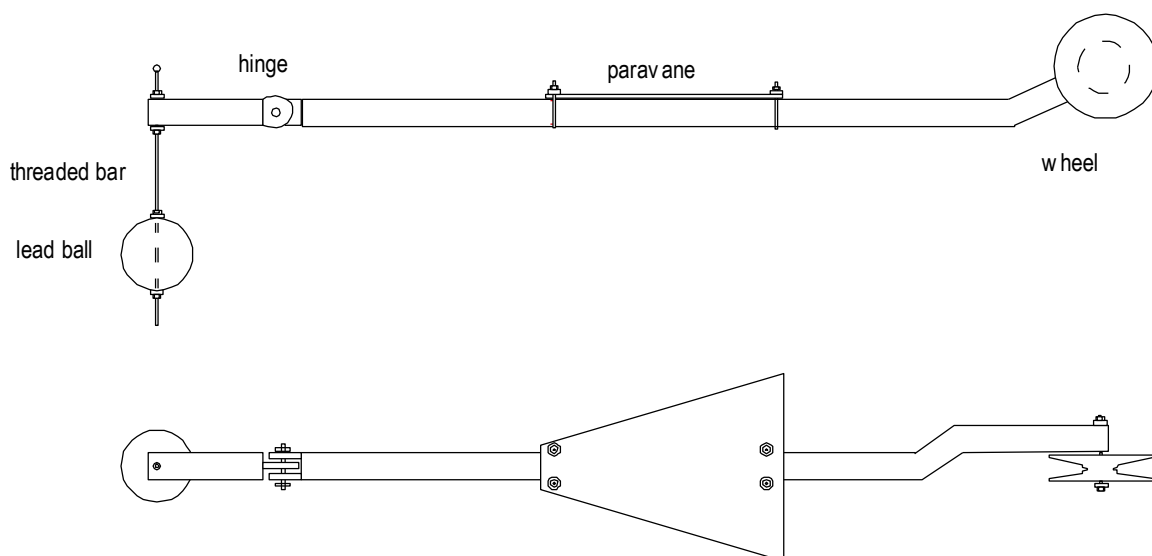

Figure 2. Schematic diagram of the underwater setter with a wheel as tested.

Methods – setter with a wheel

Five trips were undertaken, just outside Leigh, on two snapper longline vessels. Both vessels were set up with a setter tow cable, winch, and block on the starboard quarter, with the longline set from the centre of the vessel. Backbone was either 1.8 or 2.2mm monofilament nylon with stoppers every 2.0 m.

Developments were aimed at producing a clip and wheel combination that meshed and turned snoods entering the setter outwards so that hooks passed consistently beside the wheel.

Each trip involved deployment of a series of three to six short lines through the setter. Vessel speed over the ground, engine revolutions, and cable length and angle were recorded as these were varied. For trips one to three, line tension was classified as low (free spooling drum as per normal shooting conditions) medium, or high. During trips four and five, line tension was recorded using a set of spring scales on the shooting block (Figure 3).

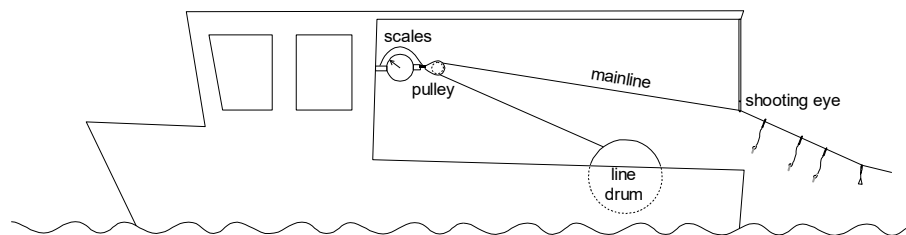

Figure 3. Schematic diagram showing measurement of line tension.

Between lines the setter was recovered and video footage was downloaded and reviewed. This provided the opportunity to make alterations to the setter and gear configuration for the subsequent set.

Between trips more involved changes were made to the setter, including modifying the wheel size and shape and altering the paravane arrangement. Each trip trialled a different clip design and wheel combination and an iterative process was followed to improve clip and wheel design and performance.

Video was reviewed at 0.5 times normal speed and frame by frame, to observe the passage of clips and fishing gear through the setter. This allowed clip performance to be assessed and potential improvements in clip shape and design to be identified. Bench testing ashore also allowed for clip design to be tested and refined.

Results – setter with a wheel

Trip by trip results and analysis are presented in Appendix 1, and summarised here.

Initially most sets were conducted with the setter deployed on 12.5 m of cable resulting in a depth of six to nine metres, at a speed of four knots. Line tension was varied manually, either using the hydraulic motor on the line drum or by applying pressure to the winch drum. Tension was generally higher than that used when normally setting gear. Later trips varied tow cable length and setter weight, achieving maximum depths of 13 m at four knots and 10 m at five knots (Appendix 1, Table 4).

Single wheels were used for all sets. Providing tension was maintained on the mainline and the mainline was kept in line with the tow cable during deployment, the mainline stayed in the wheel. However, when clips did not perform as expected, and/or weights and floats fouled on the setter the mainline would either drop off the wheel or catch on the setter. This required the set to be stopped, the setter retrieved, the line untangled if necessary, and the setter re-deployed. Most sets were interrupted in this manner several times (Appendix 1, Table 1). At this initial stage of refining clip and wheel design it was not necessary, or practical, to set large numbers of hooks through the setter. Typically, three to five short sets totalling less than 100 hooks, and including a variety of float and weight combinations provided enough video footage to identify problems and areas for improvement.

Discussion – setter with a wheel

The novel approach of using a combination of wheel and clip design to force snoods to pass around beside the wheel holds great promise in that it minimises the potential for damage to baits.

Clip and wheel design were well matched, and this approach appeared to have the desired effect of reducing the potential for bait loss. However, some baits are still likely to be lost prior to the setter and when hooks travel around the wheel rather than beside it. Eliminating tangles between the snood and the mainline before the setter would improve the proportion of clips turned beside the wheel. Similarly, further developing the ‘weight platform’ behind the wheel would allow for the setter to deal with weights and floats more readily.

Although the line tension measurements are not directly comparable between vessels, due to different deflection angles at the scales, it appears that the thicker backbone used on trip five does not hugely influence the results. In order to investigate this further, and eliminate as many variables as possible it would be necessary to conduct trials on a single vessel with two backbone diameters, ideally markedly different.

Increasing line tension caused the setters to dive deeper. This can be attributed to the line tension acting at the rear of the setter and raising the angle of attack of the paravane. Higher line tension is desirable to achieve favourable angles for the line entering the setter, and it also helped keep the line on the wheel or in the guide.

The differences in depth recorded on TDRs and the calculated depth using the tow cable angle (Table 4) are most likely attributable to measurement error, however one would expect some curve in the tow cable, especially at longer cable lengths and lower tension.

At sea trials and development of towed setter with a guide

This section summarises the outcomes from eight trips to sea developing the setter with a fixed guide, addressing the following specific objective:

1. Setting different gear configurations and bait types through the device and altering the design to accommodate the maximum range of gear.

Description of device

The guide version of the setter used an inverted U-shaped guide to apply downward force to the mainline. This was developed in attempt to strive for simplicity and take the compromise of slightly increased friction to gain the benefit of greater options for guide shape and reduced catch points.

The principle is similar to the setter with a wheel described above: The setter is weighted below the tow point to provide negative buoyancy and a bar and paravane separate the tow point from the guide and ensure the guide is held upright. A rudder corrects for the forces exerted by the longline and allows some horizontal position adjustment relative to the vessel (Figure 4). Depth and distance behind the vessel are controlled by cable length and the weight/drag combination of the setter profile.

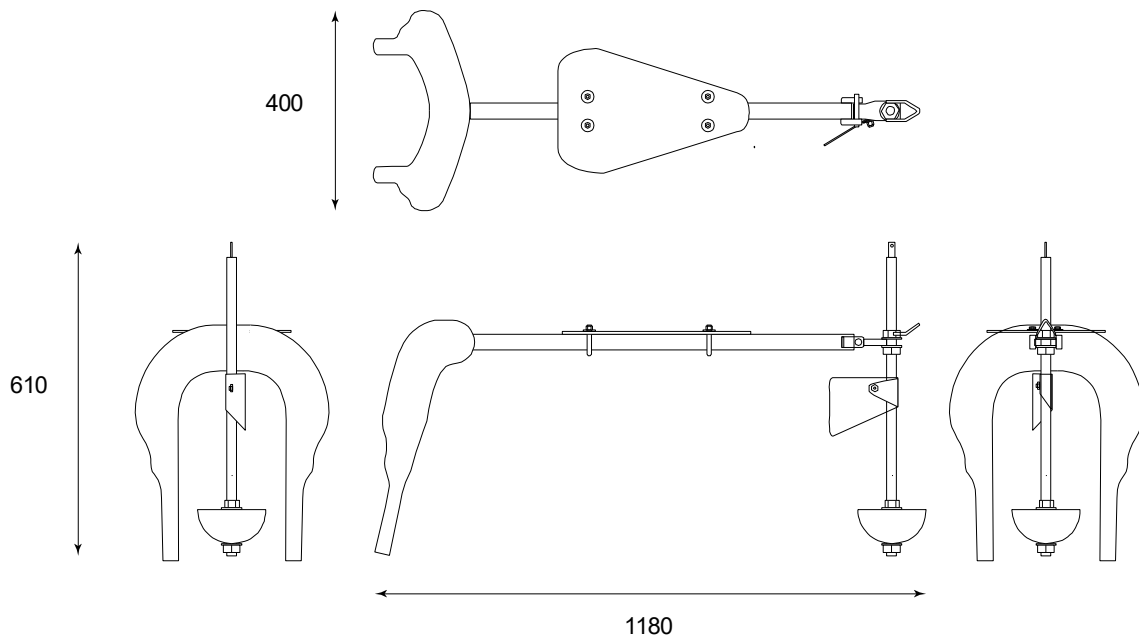

Figure 4. Schematic diagram and photograph of the underwater setter with a guide, at the start of the project.

Trip by trip methods, results, and analysis are presented in Appendix 2, and summarised here.

Methods – setter with a guide

Eight trips were undertaken outside Tauranga harbour, as part of commercial fishing operations, but with reduced hook numbers and a portion of the longline was deployed through the setter on each trip. Backbone diameter was 1.8 mm with copper crimp stoppers at 1.8 m spacing. Hooks were clipped on every 2 stoppers (3.6 m hook spacing). Larger spaces, typically 4 stoppers (8.2 m), were left beside droppers and intermediate floats

Video was reviewed at 0.5-0.8 times normal speed to observe and count the passage of hooks and baits through the setter. The fate of baits was classified into three categories as follows: 1- no visible damage, 2- damaged but still on the hook, 3- no bait as the hook left the setter. Video was reviewed frame by frame to refine the guide shape.

Between trips video footage was reviewed and modifications were made to the setter to smooth the passage of fishing gear through and around the guide. Similarly bait type, setting speed, setter depth, and line tension was adjusted between and within trips to improve performance of the setter.

Results – setter with a guide

The guide design and setter configuration were altered to iteratively improve performance. Dropper floats, weights, and intermediate surface floats were successfully deployed through the setter by incorporating a 300 mm extension before the weight or float (Appendix 2, Figure 19).

Development of the guide shape reduced bait loss by guiding most hooks and baits past the setter without contact. Occasionally snoods were tangled around the mainline before reaching the setter. This caused baits to pass through the guide, resulting in some bait loss. Tangled snoods occasionally caught around the guide, causing the mainline to be pulled out of the setter (Appendix 2, Figure 32).

Pilchard baits were fragile and bait loss was unacceptably high, even before reaching the setter, as baits were pulled rapidly to depth (Appendix 2, Tables 8 and 10, Figures 25 and 26). Squid baits were very robust and sanma baits, especially salted, were deployed through the setter with minimal loss (Appendix 2, Table 10).

High line tension reduced the curvature in the mainline between the vessel and the setter (Appendix 2, Figure 31) allowing the setter to run at deeper depths with minimal bait loss. However, catch rates on lines set with high tension were markedly less than on lines set with low tension. Later trips focussed on minimising bait loss at low line tension and produced similar catch rates compared to gear set normally, at four knots (Appendix 2, Table 11). Increasing the setting speed to 5.5 knots increased bait loss and reduced catch rates compared to normal gear, but patchy fishing confounded comparison (Appendix 2, Table 12).

At low line tension the setter operated at depth of seven to nine metres at speeds of four to five knots on 17.5 – 20 m of tow cable.

Discussion – setter with a guide

The setter with a guide has several adjustable components (Appendix 2, Figure 33), all of which influence performance. Data collected has allowed an understanding as to how these settings, combined with line tension, cable length, and setting speed influence the passage of fishing gear through the setter. In turn different configurations produce different depths, bait retention rates, catch rates, and bait returns.

A series of improvements have shown that deploying sanma and squid baits at depth is achievable, however setting lines with low line tension appears key to maintaining catch rates. Reliably achieving this at speeds over four knots will require further refinement of the setter configuration and accurate monitoring and control of line tension.

Overall Conclusions

Identifying and overcoming the challenges of deploying bottom longline gear at depth is not easy to model or predict, and there appears to be no substitute for following a trial and error approach. Having a team with a broad experience base in fishing, engineering, and mitigation has resulted in consistent progress.

The concept of matching clip design to wheel shape shows promise but still requires significant development to turn clips consistently around the wheel and shield the wheel to prevent catchups caused by tangled snoods. Deploying floats and weights appears achievable, but requires further development to achieve consistent performance.

Developing the guide shape has resulted in most snoods passing beside the setter, with baits only infrequently contacting the setter.

Both versions are vulnerable to bait loss prior to the setter as baits are pulled to depth at speed. Similarly, the snood may wrap around the mainline at this stage, causing hooks to pass through the wheel or guide, or occasionally cause the setter with a wheel catch up or the setter with a guide to drop the mainline.

Setting baits at depth with high line tension does not, unfortunately, seem to catch fish as well as baits deployed with low line tension. This is indicated by lower catch rates, and higher bait return rates on gear deployed through the setter with a guide at high line tension, compared to gear set normally with minimal line tension.

Setting gear through the setter with a guide at low line tension is more challenging and will require finer adjustments of the different components of the setter, and likely some trade off in setting speed and depth in order to maintain bait condition for sanma baits.

Bait loss prior to, and at, the setter is still likely to occur, however results to date suggest that this could be kept within commercially viable bounds for squid and sanma baits.

Next steps

Originally the proposed work schedule included setting a series of hookless baits at different depths and recording bird behavioural response, to provide some indication of setter efficacy and the depth required to deploy baits safely. Given the interactions with birds to date, and the bird activity recorded in response to bait scraps lost during setting, both with and without the setter, this no longer seems a prudent course of action.

Alternatively, we suggest further work should focus on continuing to refine the setter with a guide to set baits with lower line tension.

To date line tension has been measured on each vessel, in slightly different ways, in a repeatable manner. We propose to develop a meter to enable tension measurements to be made between vessels throughout the set.

In the longer term, trialling the setter across different vessels, with a range of bait types, against gear set normally, would allow for a robust data set describing the effect on catch rates. This would provide an understanding of how meeting the prescribed mitigation standards by using the setter impacts the fishing operation.

In order to transfer the setter between vessels it may be necessary to develop a method of controlling line tension for different winch setups.

Acknowledgements

The authors would like to thank the following people:

Skippers and crews of the vessels involved, particularly for their professionalism and flexibility.

The engineers involved.

Igor Debski, Trude Hellesland, and Ian Angus from DOC for their support and advice throughout the project.

Government funding was through the Department of Conservation, Conservation Services Programme.

References

ACAP, 2019. ACAP Review and Best Practice Advice for Reducing the Impact of Demersal Longline Fisheries on Seabirds. Reviewed at the Eleventh Meeting of the Advisory Committee Florianópolis, Brazil, 13 –17 May 2019.

FNZ, 2019. Mitigation Standards to Reduce the Incidental Captures of Seabirds in New Zealand Commercial Fisheries Bottom longline (hand baiting). Retrieved from www.mpi.govt.nz/dmsdocument/38012-mitigation-standards-hand-baiting-bottom-longline-vessels

Gilman, E., Boggs, C., Brothers, N. 2003. Performance assessment of an underwater setting chute to mitigate seabird bycatch in the Hawaii pelagic longline tuna fishery. *Ocean & Coastal Management* 46: 985–1010.

Goad, D., Temple, S., Williamson, J., 2010. MIT 2009/01 Development of mitigation strategies: Inshore fisheries. Retrieved from: www.doc.govt.nz/globalassets/documents/conservation/marine-and-coastal/fishing/twg/2009-01-mit-inshore-fisheries.pdf

Goad, D., 2011. Trialling the ‘Kellian Device’. Setting bottom longlines underwater A report prepared by Vita Maris for the Department of Conservation, Wellington.

Goad, D., Debski, I., Potts, J., 2019. Hookpod-mini: a smaller potential solution to mitigate seabird bycatch in pelagic longline fisheries. *Endangered Species Research* 39:1–8. doi: 10.3354/esr00953

Hookpod, 2020. www.hookpod.com

MPI 2018. Fisheries (Seabird Mitigation Measures—Bottom Longlines) Circular 2018. Retrieved from <http://legislation.govt.nz/regulation/public/2018/0116/latest/LMS57231.html>

Oceansmart, 2011. www.Oceansmart.com.au

Pierre, J., 2018. Conservation Services Programme Project MIT2017-01: Protected Species Liaison Coordination Final Report. Report prepared for the Department of Conservation, Wellington. Retrieved from: www.doc.govt.nz/contentassets/4d83b3260a4d43d5afe98dcf193b90b5/mit2017-01-ps-coordination-final-report.pdf

Pierre, J., Goad, D., Thompson, F., Abraham, E., 2012. Reducing seabird bycatch in inshore bottom longline fisheries. Draft Final Report Conservation Services Programme Projects MIT2011-03 and MIT2012-01. Retrieved from: www.doc.govt.nz/our-work/conservation-services-programme/csp-reports/2012-13/reducing-seabird-bycatch-in-inshore-bottom-longline-fisheries/

RNZ, 2020. www.rnz.co.nz/news/national/409271/numbers-of-seabirds-killed-as-commercial-bycatch-largely-unchanged.

Robertson, G., Candy, S. G. and Hall, S. (2013). New branch line weighting regimes to reduce the risk of seabird mortality in pelagic longline fisheries without affecting fish catch. *Aquatic Conservation of Marine and Freshwater Ecosystems*, 23, 885–900.

Robertson, G., Candy, S., G., Wienecke, B., & Lawton, K. (2010). Experimental determinations of factors affecting the sink rates of baited hooks to minimise seabird mortality in pelagic long-line fisheries. *Aquatic Conservation: Marine and Freshwater Ecosystems*, 20, 632–643.

Robertson, G., Ashworth, P., 2010. Progress report on the development and testing of the underwater bait setter for pelagic longline fisheries. Agreement on the Conservation of Albatrosses and Petrels. Third Meeting of the Seabird Bycatch Working Group. Mar del Plata, Argentina, 8 –9 April 2010.

Ryan, P., Watkins, B., 2002: Reducing incidental mortality of seabirds with an underwater longline setting funnel. *Biological Conservation* 104: 127–131.

Webber, D., 2020. A spatially explicit fisheries risk assessment (SEFRA) of New Zealand seabirds. Report prepared for Fisheries New Zealand, Wellington.

Appendix 1 Trip by trip summary – setter with a wheel

Trip 1W

Plastic and wire clips were designed and produced for testing (Figure 5). A nylon wheel was designed to match the clips (Figure 6), so that the two components fitted together to turn the end of the clip outwards as it passed around the wheel (Figure 7), allowing snoods, baits and hooks to pass beside the wheel.

Initial sets showed that clip shape could turn the snood beside the wheel. However, the large surface area of the clip was thought to be causing problems including providing too much resistance in the water, and the flat surface caused the clip to behave erratically when pulled downwards through the water. Weights and floats both entered the setter from astern, sometimes passing over the wheel, and sometimes causing the line to be pushed out of the wheel.



Figure 5. Photograph showing design of clip 1



Figure 6. Photograph showing design of wheel 1.

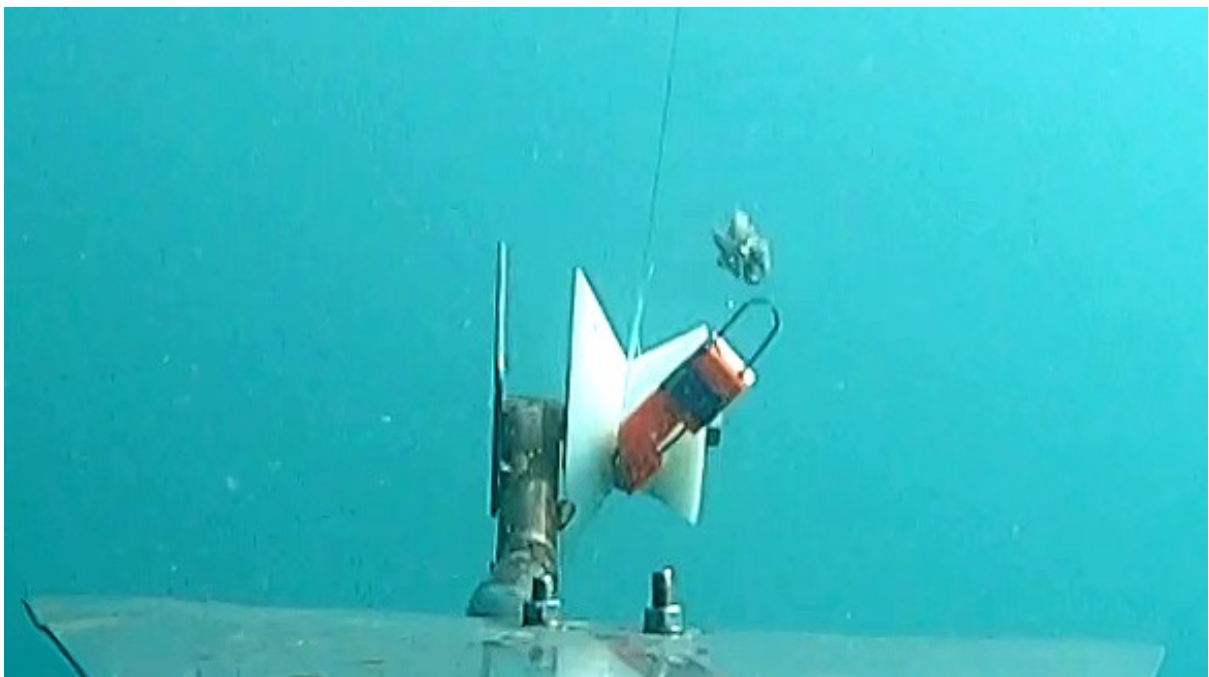
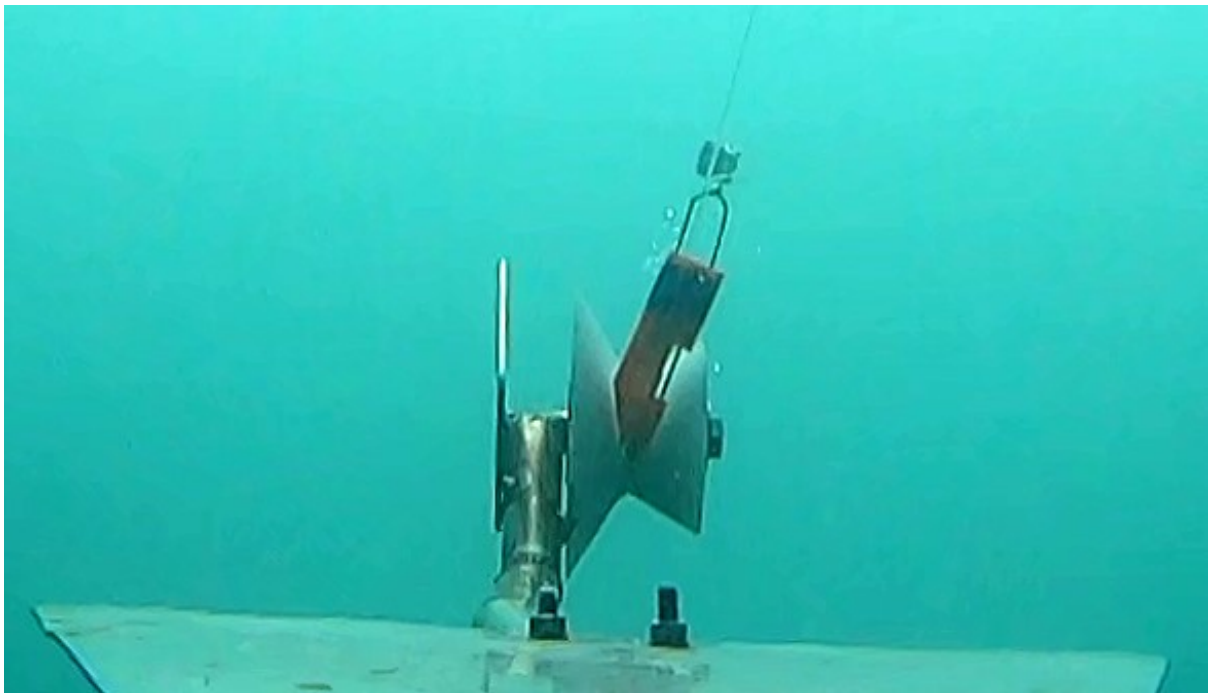

Figure 7. Photograph sequence from trip 1W, showing clip turning snood and bait outside the wheel.

Trip 2W

Modifications for the second trip included trialling a second wheel design with the plastic clips (Figure 8), and a wire clip (Figure 9) with a third wheel design (Figure 10).

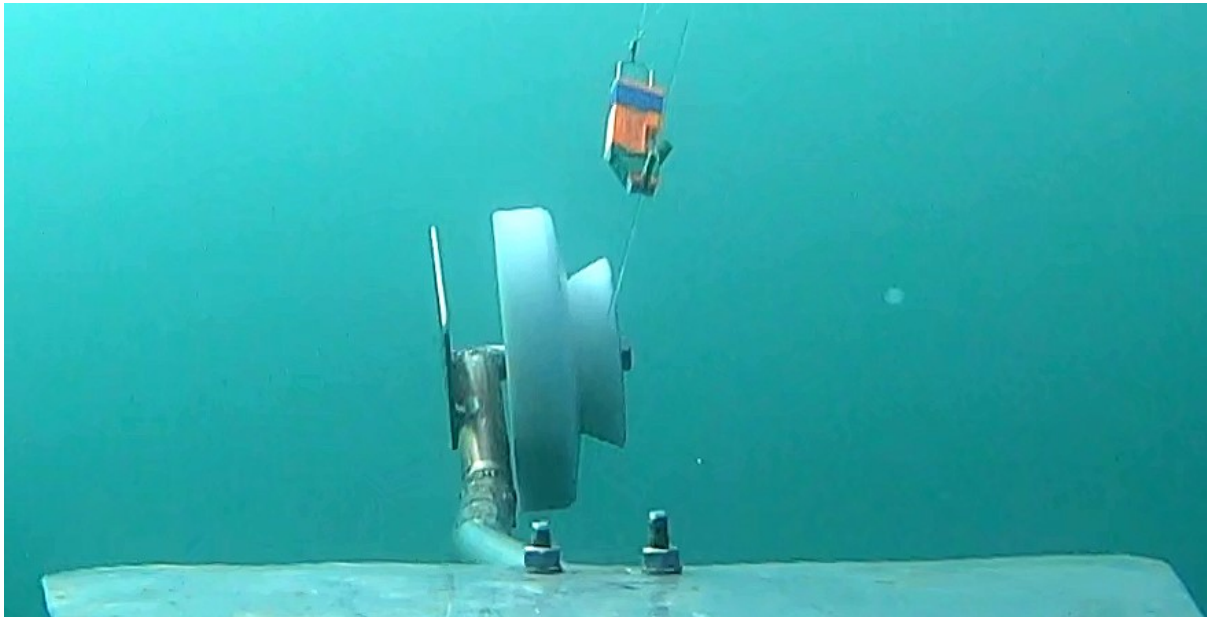

Figure 8. Photograph showing second wheel design with plastic clip, taken during trip 2W.



Figure 9. Photographs showing second clip design, and variations tested during trip 2W.

The plastic clips performed better with an asymmetrical wheel but still encountered similar problems to trip 1 (Table 1). The wire clips offered much less resistance, meshed with the wheel differently, and behaved more consistently, but did not match the wheel sufficiently well to turn the snoods outwards consistently (Figure 10).

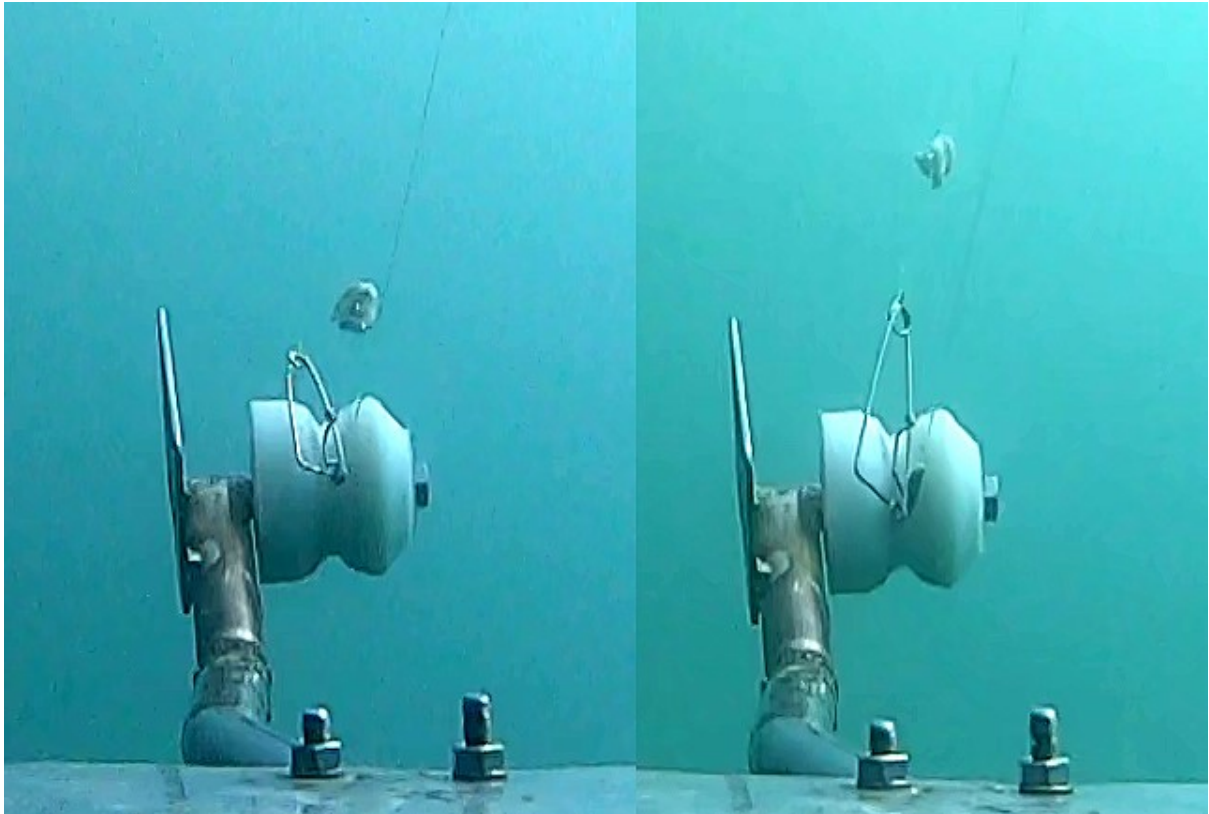

Figure 10. Photographs showing third wheel design and second clip design, taken during trip 2W

Some floats passed around the wheel with no problems but some came between the line and the setter and forced the line out of the wheel (Figure 11).

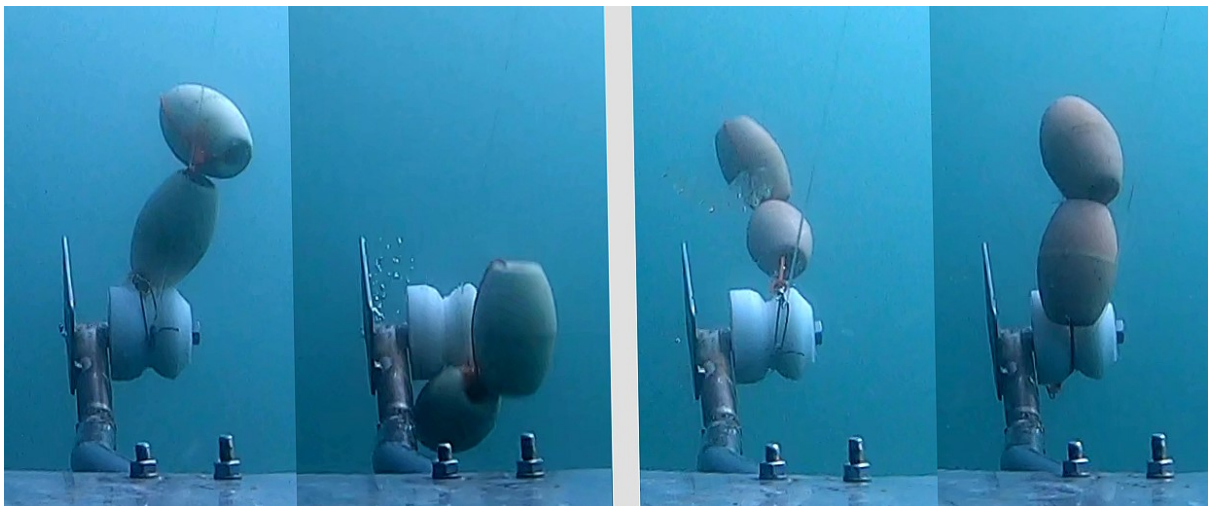

Figure 11. Two photo sequences showing floats passing around the wheel (left) and pushing the line off the wheel (right).

Table 1. Summary of trips 1W and 2W

Trip / Set	Deployment	Wheel design	Clip design	Cable length (m)	Cable angle (degrees)	Longline tension	Speed (knots)	TDR depth (m)	End of deployment	Notes
1 / 1	1	1	1	8	45	med	3	6.3	hook caught between wheel and setter	too much water resistance to turn clips, some baits through wheel. small weight dropped behind setter then pulled through,
	2			8,14	34	med	4	6.0, 7.2	floats forced line off wheel.	
1 / 2	1	1	1	9	40	med	4	6	dropper float around wheel	
	2			9		med+	4	5.8	end of trial	
1 / 3	1	1	1	11	42	med+	3.1	8.5	hook beside wheel and setter	
	2			10,12.5		med+		8, 9.3	floats lifted line out of wheel clip sideways, forced line off wheel.	
2 / 1	1	2	1	12.5	30	med	4	9	hook caught around backbone, snood looped around wheel	
	2			12.5		med	4	8.2	0.7 kg weight pulled line off wheel	
	3			12.5		high	4	6		
2 / 2	1	3	2	12.5	30	med +	4	9.3	clip forced line of wheel weight behind setter jumping stoppers, 2nd pulled line out of wheel.	
	2			12.5		med +	4	9		
2 / 3	1	3	2	12.5	33	low	4	8	3 kg weight stuck behind setter	digger track links
	2			12.5		low	4	7.5	6 kg weight stuck behind setter	2 x digger tracks
	3			12.5		low	4	7.8	mainline caught beside wheel	5kg block under
	4			12.5		low	4	7.2	floats forced line off wheel weight pulled line off side of wheel	
	5			12.5		low	4	7.3	floats forced line off wheel (OK one side of mainline but not the other)	
	6			12.5		low	4	8		
	7			12.5		low	4	7.6	floats forced line off wheel	some small weights pulled around wheel OK

Trip 3W

The wire clips were redesigned for the third trip (Figure 12) and trialled with the third wheel design.



Figure 12. Photograph showing third clip design.

These clips performed well and, providing the snood was not tangled, the clips tended to sit astride the cheek of the wheel and then turned the snood around the wheel (Figure 13). Several snoods were tangled around the mainline between leaving the boat and reaching the camera on the setter.

Floats and weights still entered the setter from astern. Smaller weights and floats were able to be turned around the wheel at times, but forced the mainline out of the setter at other times (Table 2). The variable performance depended largely on which side of the wheel they passed and whether they were pulled over the wheel or beside the wheel.

Large weights tended to require too much force to be pulled up and over the wheel, necessitating retrieval and redeployment of the setter.

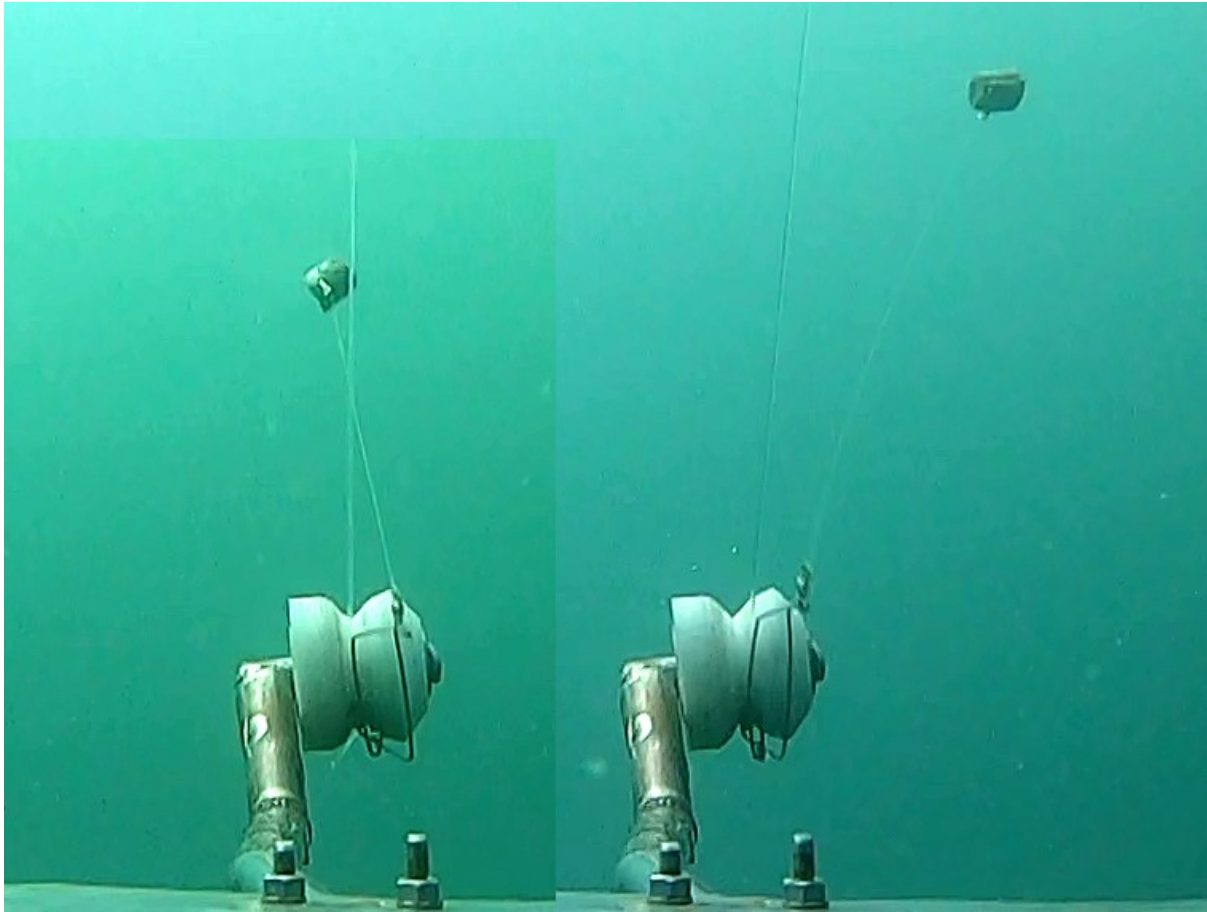

Figure 13. Photographs showing third wheel design and third clip design, taken during trip 3W, note how the clip with the angled base turned the snood outwards more.

Trip 4W

The wire clip was further refined to spin more freely on the mainline, and the geometry matched to the second wheel design (Figure 14). A second paravane was fitted behind the wheel, to stop weights falling behind the wheel (Figure 15).



Figure 14. Photograph showing fourth clip design, note loop at top allowing it to spin freely on mainline

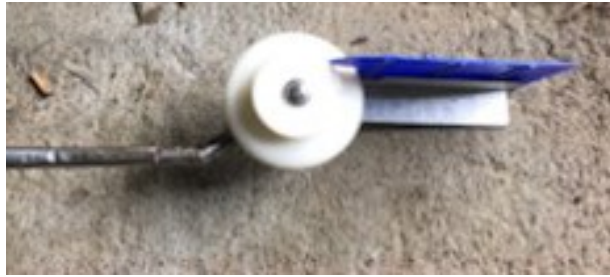

Figure 15. Photograph showing paravane added behind the wheel.

The revised clip design worked well with the wheel (Figure 16) however, some snoods were still twisting around the mainline, causing hooks and baits to be pulled around the wheel and occasionally catchups occurred (Table 2). The concept of a platform/paravane to catch the weights showed promise but needed to be wider as weights fell off it sideways (Figure 17). A larger platform was made up at sea but was not sufficiently rigid.

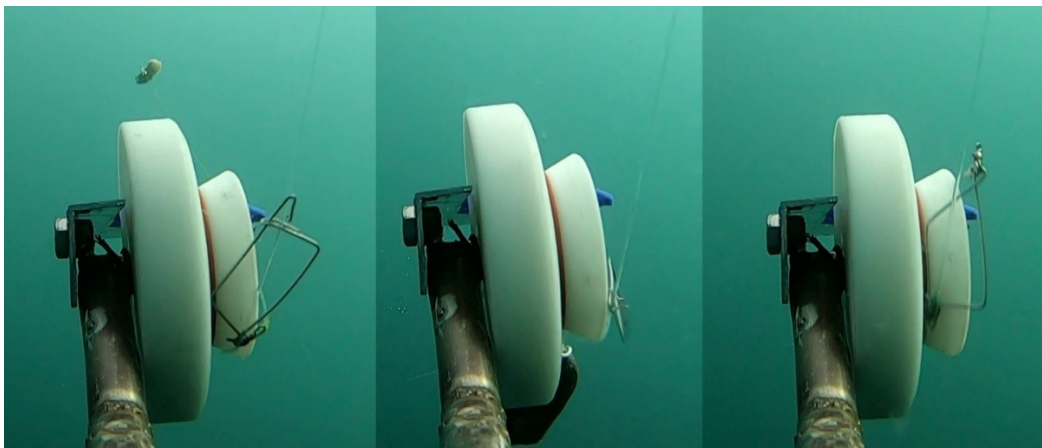

Figure 16. Photographs showing (from left to right) snood tangled around mainline at clip and clip going 'backwards' around wheel, weight dropping the line off the wheel, clip landing on wheel and guiding snood beside wheel.

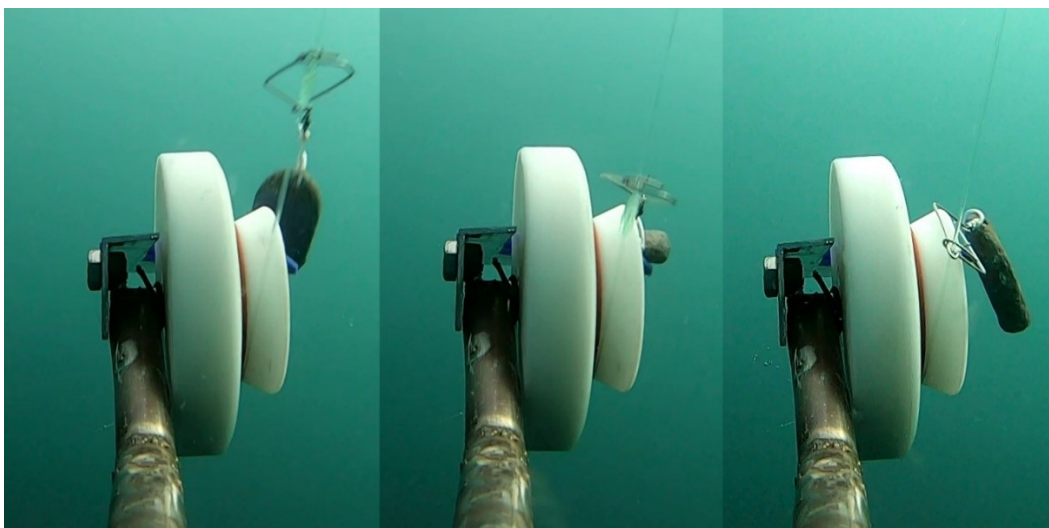

Figure 17. Photograph sequence showing weight platform (in blue behind the wheel) catching a weight momentarily.

Table 2. Summary of trips 3W and 4W

Trip / Set	Deployment	Wheel design	Clip design	Cable length (m)	Cable angle (degrees)	Longline tension	Speed (knots)	TDR depth (m)	End of deployment	Notes		
3 / 1	1	3	3	12.5	33	med	4	8.3	hook tangled around mainline, snood looped around wheel.			
	2			12.5				4	7.8	snood tangled around mainline, clip went into wheel swivel first and forced line off		
	3			14				4	8.3	floats forced line off wheel	some weights over wheel OK	
	4			12.5				4	7.7	big weight pulled line off sideways	weight jumping stoppers	
3 / 2	1	3	3	9.5		med	4	6.7	bait went through wheel and pushed line off			
	2			12.5		low		4	7.6	3.5 kg weight stuck behind wheel	0.7 kg weight and floats jumping stoppers behind wheel	
3 / 3	1	3	3	12.5		low	4	7.6	25 hooks through OK			
	1			12.5				28	4	6	weld not finished = jamming snoods	Setter with guide
4 / 1	1	2	4	12.5		12-13	4	7.7	snood twisted around mainline at clip, pulled line off.	2nd paravane on		
	2			12.5				35	12-14	4	7.5	0.7 kg lead weight turned line off roller
4 / 2	1	2	4	12.5		10	4	7.7	snood dropped line, setter not upright	larger 2nd paravane to hold weights, rod bent, not sitting upright		
	2			12.5				36	3-4	8.4	snood dropped line, setter not upright	less tension, snoods up against stoppers
	3			12.5				37	3-4	7.7	bait round wheel pushed mainline out	paravane off
	4			12.5				37	6	7.8	hook tangled around mainline, loop caught around wheel	

Unsurprisingly, more weight, slower speeds and more cable allowed the setter to swim at deeper depths, with a shallower tow cable angle (Table 3). Less predictably an increase in tension resulted in the setter swimming deeper (Table 3).

Table 3. Results from trip 4W, trialling different setter configurations.

Trip / Set	Deployment	Wheel design	Clip design	Weight on setter (kg)	Cable length (m)	Cable angle (degrees)	Longline tension	Speed (knots)	TDR depth (m)
4 / 3	1	2	4	15	12.5	33	7	4	7.5
				15	17.5	28	7	4	9.8
				15	22.5	21	7	4	11.6
				15	12.5	30	7.5	5	6.4
				15	12.5		12-13	5	8
				15	17.5	24	7.5	5	8.2
				15	22.5	21	7.5	5	10
4 / 4	1	2	4	30	10	47	14	5	6.5

Trip 5W

Trip five was conducted on a different vessel, to look at the effect of using 2.5 mm diameter backbone. The relationship between setter weight, line tension, cable length, and setting speed and how these factors influenced the depth of the setter, the angle at which the longline entered the setter, and the passage of snoods was investigated (Figure 18). A series of trials were conducted, varying setter weight, cable length, line drum tension, and setting speed, and repeated with both the setter with a wheel and the setter with a guide. Response variables recorded included cable angle, line tension, and setter depth from the average of two TDR records. Cable angle was also used to calculate distance astern and depth. At each combination ten hooks baited with pilchard were deployed through the setter with a guide to examine the passage of snoods and provide some indication of bait loss.

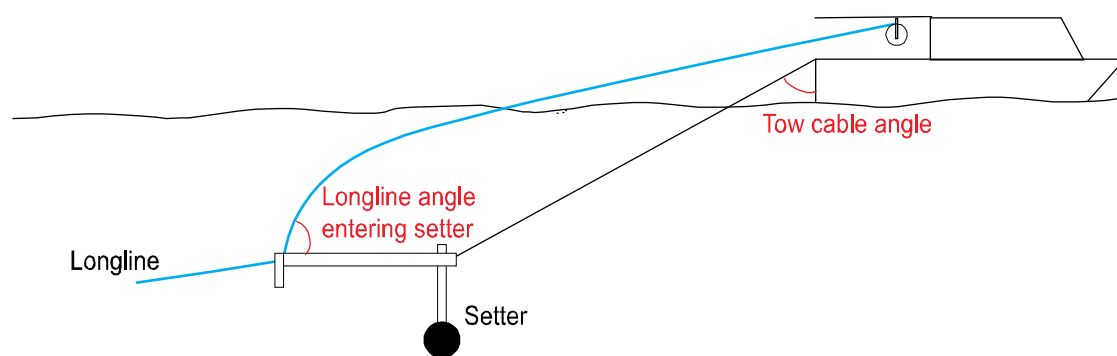

Figure 18. Diagram showing angles measured in Table 4.

Not all configurations were tested with the setter with a guide (Table 4) because the line came out of the setter at lower speeds and low tensions with less weight. This was likely due to the small rudder angle on the setter, and increasing this from 20 to 40 degrees solved this problem and allowed low tension results to be recorded at faster speeds and with the larger weight.

A similar pattern was observed to that on trip 4, however with more combinations tested a fuller picture was built up of the behaviour under different settings (Table 4).

Two flesh footed shearwaters were caught during trip 5, hooked through the beak. For one bird hook counts were not made to enable the position be related to line configuration and setter depth, for the second one the setter was operating at about five metres depth with three-kilogram weights added every 25 hooks.

Some bird activity was observed whilst setting, with less than five birds active behind the setter and tori line, and birds were likely attracted to loose baits lost at the setter. The trial may have caused increased bycatch risk through setting at day and loosing baits. However, the trial will have reduced risk by achieving a greater sink rate under the aerial extent of the tori line compared to gear set normally.

Table 4. Results from trip 5W, trialling different setter configurations.

Device type	Weight (kg) on device	Speed (knots)	Towline length (m)	Longline tension (kg)	Towline angle (deg)	TDR depth (m)	Line angle entering setter	Calculated depth (m)	Calculated distance astern (m)
Guide	7.5	4.0	10.0	5.5	63	4.0	134	4.5	8.9
Guide	7.5	4.0	10.0	12.0	62	4.1	87	4.7	8.8
Guide	7.5	4.0	15.0	5.5	63	6.0	120	6.8	13.4
Guide	7.5	4.1	15.0	13.0	63	6.2	120	6.8	13.4
Guide	7.5	4.1	20.0	6.0	70	7.3	109	6.8	18.8
Guide	7.5	4.1	20.0	12.0	70	7.7	72	6.8	18.8
Guide	7.5	5.3	10.0	9.0	70	3.2	95	3.4	9.4
Guide	7.5	5.3	10.0	13.0	73	3.3	61	2.9	9.6
Guide	7.5	5.3	15.0	8.0	72	4.4	78	4.6	14.3
Guide	7.5	5.3	15.0	13.0	74	4.5	59	4.1	14.4
Guide	7.5	5.3	20.0	6.0	75	5.3	65	5.2	19.3
Guide	7.5	5.3	20.0	13.0	75	5.7	56	5.2	19.3
Guide	22.5	4.0	10.0	6.0	45	6.2	142	7.1	7.1
Guide	22.5	4.0	10.0	10.0	48	6.7	91	6.7	7.4
Guide	22.5	4.0	15.0	10.0	44	9.2	102	10.8	10.4
Guide	22.5	4.0	20.0	10.5	50	12.0	129	12.9	15.3
Guide	22.5	5.0	10.0	13.0	62	4.6	135	4.7	8.8
Guide	22.5	5.0	15.0	14.0	66	6.7	89	6.1	13.7
Guide	22.5	5.0	20.0	15.0	70	10.7	77	6.8	18.8
Wheel	15.0	4.0	10.0	4.5	54	6.2		5.9	8.1
Wheel	15.0	4.0	10.0	9.0	58	6.5		5.3	8.5
Wheel	15.0	4.0	15.0	5.0	60	8.5		7.5	13.0
Wheel	15.0	4.0	15.0	9.0	60	8.7		7.5	13.0
Wheel	15.0	4.0	16.0	5.0	61	9.1		7.8	14.0
Wheel	15.0	4.0	16.0	9.0	60	9.4		8.0	13.9
Wheel	15.0	5.0	10.0	9.0	62	4.9		4.7	8.8
Wheel	15.0	5.0	10.0	13.5	62	5.2		4.7	8.8
Wheel	15.0	5.0	15.0	8.0	62	7.6		7.0	13.2
Wheel	15.0	5.0	15.0	12.5	66	6.5		6.1	13.7
Wheel	15.0	5.0	16.0	7.5	70	6.3		5.5	15.0
Wheel	15.0	5.0	16.0	13.0	66	8.1		6.5	14.6
Wheel	15.0	7.0	10.0	22.0	70	3.3		3.4	9.4
Wheel	30.0	4.3	10.0	5.0	44	7.1		7.2	6.9
Wheel	30.0	4.3	10.0	9.0	46	7.1		6.9	7.2
Wheel	30.0	4.3	15.0	5.5	56	10.1		8.4	12.4
Wheel	30.0	4.3	15.0	9.0	54	10.0		8.8	12.1
Wheel	30.0	4.3	20.0	6.0	48	12.9		13.4	14.9
Wheel	30.0	4.3	20.0	9.5	57	12.8		10.9	16.8
Wheel	30.0	5.0	10.0	8.0	54	6.3		5.9	8.1
Wheel	30.0	5.0	10.0	14.0	49	6.5		6.6	7.5
Wheel	30.0	5.0	15.0	10.0	61	8.7		7.3	13.1
Wheel	30.0	5.0	15.0	14.0	53	9.2		9.0	12.0
Wheel	30.0	5.0	20.0	8.0	62	10.2		9.4	17.7
Wheel	30.0	5.0	20.0	16.5	62	9.8		9.4	17.7
Wheel	30.0	7.0	10.0	22.0	50	4.7		6.4	7.7

Appendix 2. Trip by trip summary - setter with a guide

Trip 1G

Trip specific objectives:

Compare bait retention and catch rates between gear deployed through the setter and gear deployed normally.

Refine setter configuration, specifically examining the combination of cable length, cable angle, setting speed, and depth.

Methods

A two-part longline was set, just after sunrise outside Tauranga, from 30 m to 40 m water depth, with two turns. The first 500 hooks comprised a normal gear setup with a float-weight combination every 30 hooks. The second 500 hooks were deployed through the setter with the same weight and float setup, but with floats on longer ropes. Float rope lengths were varied between 300 and 600 mm for the second half of the set, which was longer than the vessel's normal setup of 100 mm ropes. Sanma baits were used for all hooks set. Two intermediate floats were deployed, one normally and one through the setter (Figure 19)

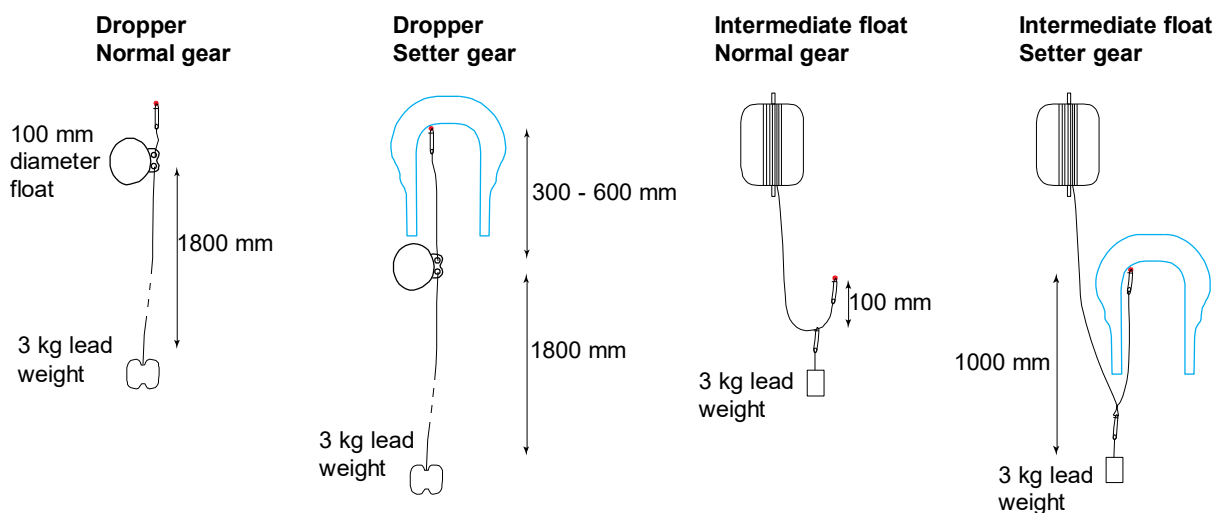

Figure 19. Schematic diagram showing subsurface 'dropper' and surface 'intermediate' float setups used during trials. The longline is shown in red and the underwater setter guide is shown in blue. Some dropper weights were 1.5 kg.

Two GoPro Hero 7 black cameras were attached to the setter to observe the passage of hooks, weights and floats through the guide and two TDRs were attached to record depth.

Vessel speed over the ground, engine revolutions, and cable length and angle were recorded as these were varied during the set.

Video was reviewed at 0.8 times normal speed to observe and count the passage of hooks and baits through the setter. The fate of baits was classified into three categories as follows: 1- no visible damage, 2- damaged but still on the hook, 3- no bait as the hook left the setter. Video was reviewed frame by frame to refine the guide shape.

The number of baits returned on the longline at the haul, and the fish catch was recorded for each treatment.

Results

Line tension was controlled using a weight on the line drum brake, higher than would be used for normal fishing operations.

Deploying the setter part way through the set was reasonably easy. Speed was reduced and no hooks were clipped on whilst the setter was placed over the line and deployed to depth; bare longline was run out during this time.

The setter was set up with 10 degrees of starboard rudder and deployed on 17.5 m of 3 mm stainless steel cable, measured from the sea surface to the setter. The cable angle was measured at 65 degrees, at 3 knots, giving a calculated depth of 7.4 m. Average depth from two TDR readings was 7.6-7.85 m (Figure 20).

The first dropper weight passed to port of the setter weight, and tangled. The setter was retrieved, the weight unwound and redeployed with the rudder set 15 degrees to port.

Cable angle and TDR measurements of depth again correlated well with the setter running at 8 m depth initially at 2.3 knots, then 7.5 m at 3.5 knots and 7 m at 4.3 knots (Figure 20).

All gear passed smoothly through the setter except for two hooks at the slowest speed, which hesitated at the setter until the following stopper pulled them through. While 'waiting' up against the setter they trailed astern and the hook caught on the mainline. Above three knots, hooks were up against the stoppers at the setter and went through smoothly. Most snoods followed a path down the leg of the guide and then around the lower portion of the upright 'leg'. Two droppers with lighter 1.5kg weights caught momentarily on the setter and then passed under the guide. Those with larger weights pulled the float directly below the guide as per Figure 19. The longer ropes allowed floats to pass below the guide without contact.

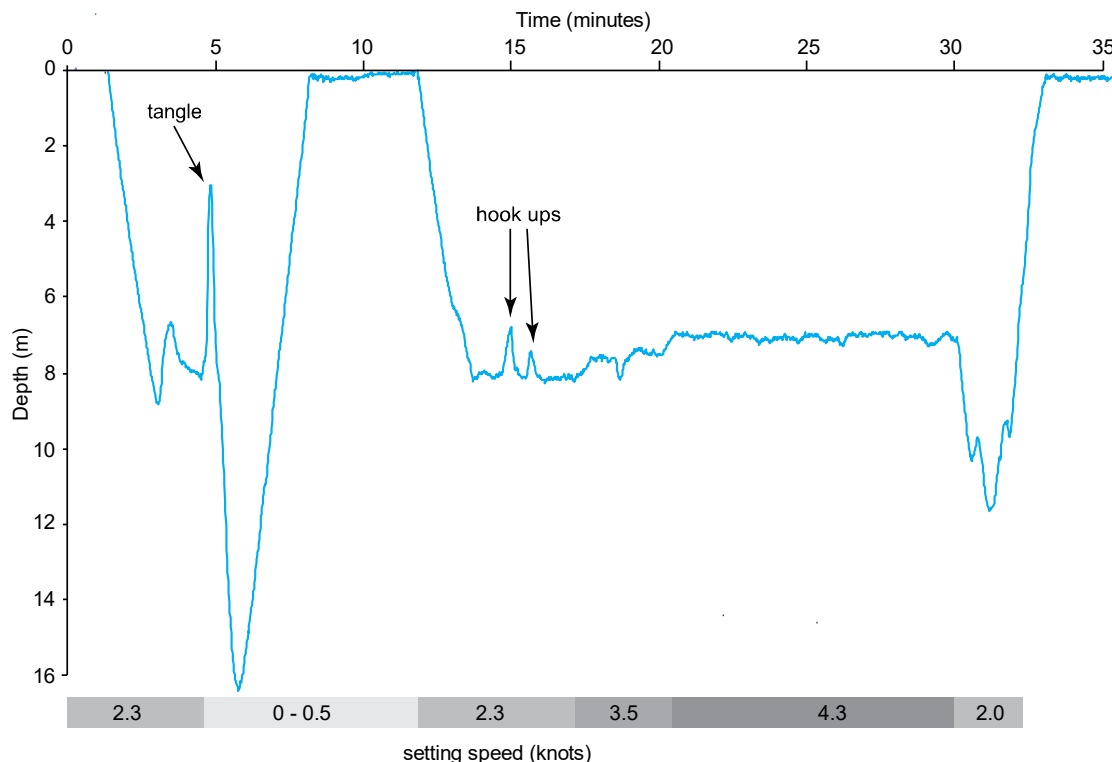

Figure 20. Setter depth over time during trip 1W. The boat was slowed down and stopped between 5 and 10 minutes to recover, untangle, and redeploy the setter.

Catches were patchy and low, with noticeably less fish on the gear deployed through the setter, though more baits were returned on the line set through the setter (Table 5).

Table 5. Counts of catch and bait returns at the haul from gear deployed normally and gear deployed through the setter.

	Gear deployed normally	Gear deployed through setter
Catch		
Snapper	73	18
Gurnard	2	
Kingfish	9	10
Trevally	1	
Barracouta	2	
Kahawai	1	
Snake eel	1	1
Eagle ray		1
Mako shark		1
Sponge		3
Starfish	8	11
Baits returned	219	246

Bait loss through the setter was unacceptably high, and half the baits were damaged (Table 6).

Table 6. Fate of baits deployed through the setter.

Description	Count
OK - no visible damage	143
Damaged	238
Hook left setter with no bait	117

Video footage showed that the majority of damage to baits occurred as they were pulled around the narrow diameter lower portion of the guide (Figure 20 B, Figure 21). Some baits were damaged or lost when swiftly pulled down towards the setter (Figure 4, A) Some damage also occurred prior to baits reaching the view of the camera. Damage was predominantly loss of guts though also included splitting the flesh of the bait. Occasionally baits were trapped between the longline backbone and the setter (Figure 4, C).

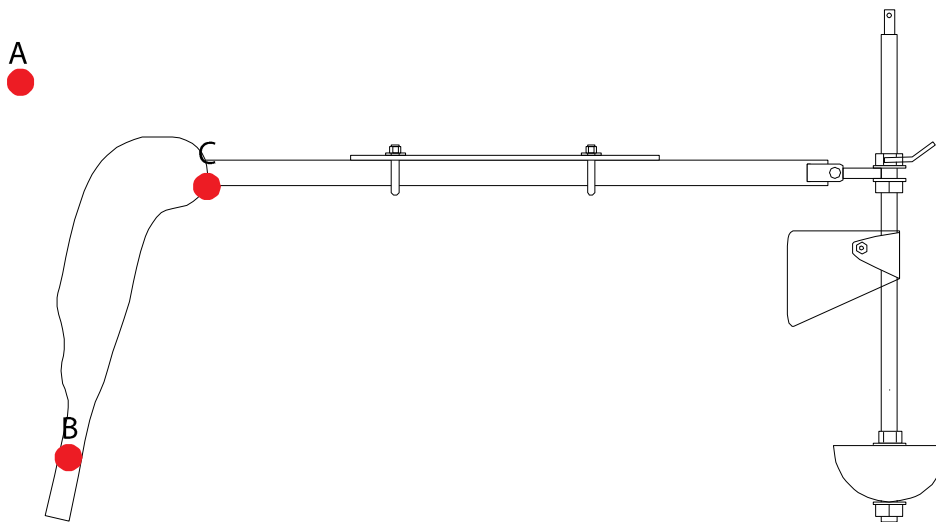
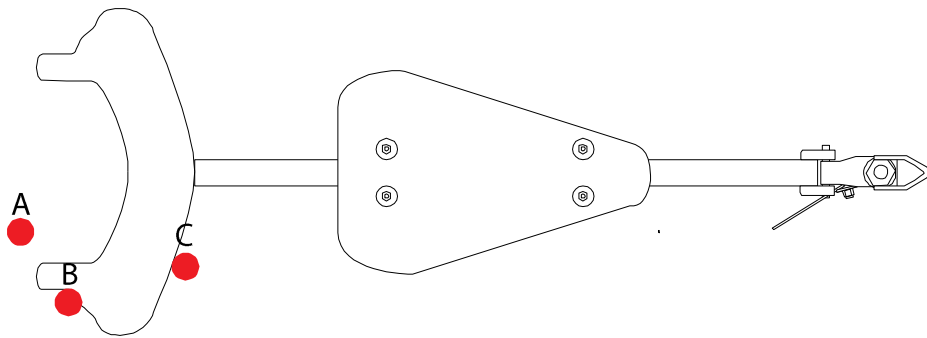

Figure 20. Areas where baits were lost or damaged. A: Bait rapidly changed direction as it was pulled into setter, B: bait wrapped around leg, C: bait squashed between longline and setter.

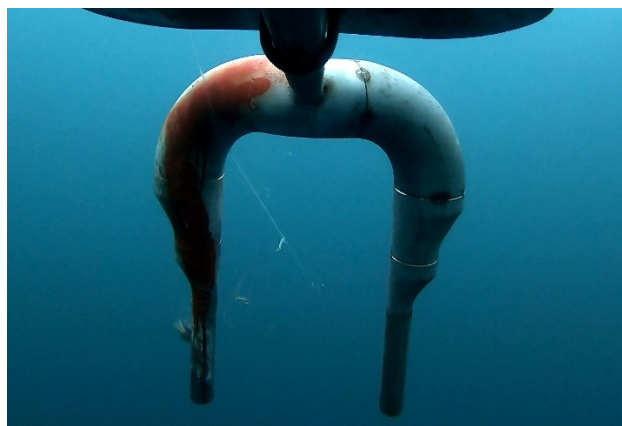

Figure 21. Bait loss as hook was pulled around the leg of the guide.

Using video footage, wear marks on the setter, and observations from on deck, the longline appeared to be entering the setter vertically (Figure 22).

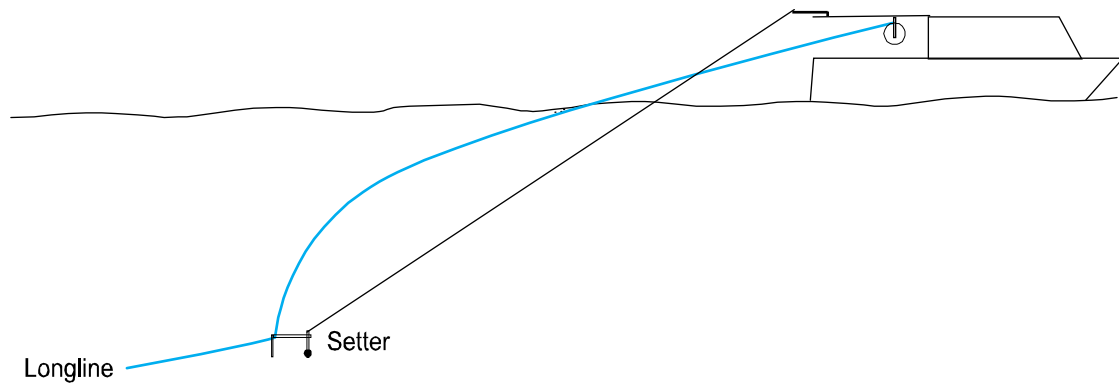

Figure 22. Estimated configuration of longline and setter.

At the end of the set the longline drum brake was released in attempt to drop the line out of the setter. This was not successful and the setter was recovered in order to deploy the float on the last end of the line.

Discussion

Initial results were in line with previous work, and the setter fitted well into normal fishing operations. Catch rates and bait return rates provided an immediate measure of performance, and represent how fishers judge fishing gear performance. However, low catch rates and patchy fishing, in this case over different depths, make these results difficult to interpret. The video footage provides a much more robust measure of performance in terms of bait loss, within the limitations of the camera field of view. Newer GoPro cameras have improved resolution and this footage was shot at 120 frames a second and 2560 x 1440 pixels. However, the speed at which baits pass through the setter, low light levels, and moderate water clarity combine to still produce some blurring of still images taken from the video. The video field of view allowed all bait to be tracked through the setter. Counting bait loss as baits leave the setter includes baits lost before entering the field of view of the cameras.

Some baits were damaged and lost at the boat as snoods were pulled from the card. The camera on the top of the setter showed some bait loss (Figure 20 A) and this is likely to be an unavoidable consequence of pulling baits rapidly downwards and forwards through the water into the setter, rather than letting them sink slowly downwards as per a normal set. Forces applied to baits, and the associated loss, will be greater at higher speeds and deeper setter depth as the baits will be pulled through the water faster. The curvature of the longline in Figure 22 exacerbates this, and can be reduced by increasing line tension. Trials have been run at higher line tension than normal fishing operations to minimise this curvature.

Bait loss as hooks wrap around the legs of the guide (Figure 20 B) may be reduced by shorter and/or larger diameter legs.

Bait loss at C (Figure 20 C) was rare and occurred if the snood was close to the longline. At higher speeds all snoods followed a path around the side of the leg. Increasing the angle between the longline and the longitudinal axis of the setter should increase the proportion of snoods passing down the side of the leg and can be achieved by increasing the rudder angle and reducing cable length.

Modifications between trips

The diameter of the legs was increased and the length of the legs reduced (Figure 23) in an attempt to reduce bait loss by pulling baits around a larger radius and having a higher proportion pass below the leg.



Figure 23. Photograph showing modifications made to the setter guide, with the shorter and larger diameter legs welded on, and the old legs removed.

Trip 2G

Trip specific objectives:

Compare the retention rates of different bait types deployed through the modified setter at 5 m depth.

Methods

Gear setup was similar to the first trip. Initially 120 hooks baited with defrosted sanma were set normally, then the setter was deployed and setting continued in the following order: 120 hooks baited with salted sanma, 120 hooks with sanma, 120 hooks with squid, and finally 120 hooks with pilchard baits. The line was set in a straight line, along the 20 m depth contour on Matakana Bank.

Cameras setup and data recording was the same as trip 1G.

Results

Weather conditions were good with 10 knots of wind and 0.5 m swell.

The setter was set up with 30 degrees of port rudder and deployed on 12.5 m of cable, measured from the sea surface to the setter. The cable angle was measured at 65 degrees, at 4.9 knots, giving a calculated depth of 5.3 m. Average depth from two TDR readings was 5.2 – 5.7 m (Figure 24).

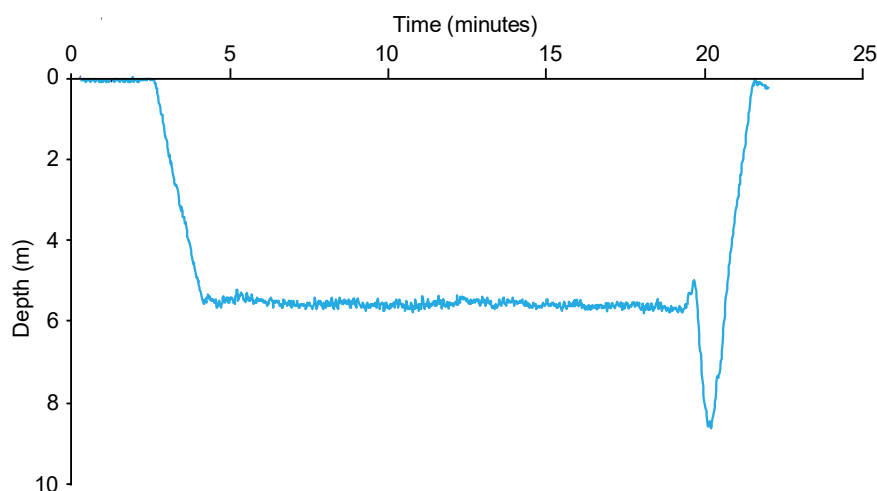

Figure 24. Setter depth over time during trip 2. Depth increased at the end of the set as the speed through the water reduced.

Gear passed smoothly through the setter with the exception of two snoods which returned with no hook, and one snood which was lost. Video footage showed one snood tangled around the longline rather than clipped on before entering the setter and two hooks catching on the open base of the leg.

Fishing was patchy and not consistent enough to provide an indication of performance of different bait types in terms of catch rates (Table 7). Bait returns varied between treatments with squid staying on hooks well, salted sanma showing highest retention of the fish baits, followed by sanma and pilchard (Table 8).

Table 7. Counts of catch and bait returns at the haul from gear baited with sanma deployed normally and gear with different bait types deployed through the setter. 120 hooks were deployed for each treatment.

Deployment Bait type	Normal	Through setter			
	Sanma	Salted sanma	Sanma	Squid	Pilchard
Catch					
Snapper		1	11	3	3
Gurnard			1	2	1
Kingfish	1				
Trevally	1	1			1
Kahawai	15			1	2
Baits returned	76	94	52	114	15

Sanma bait loss at the setter was reduced compared with trip one, and the majority of damage was lost guts. Salted sanma was more robust and squid was more robust again. Pilchard baits were larger and more fragile with unacceptably high loss and damage rates, and proportionately more damage to the flesh of the bait (Table 8).

Table 8. Fate of different bait types deployed through the setter.

Description	Salted sanma	Sanma	Squid	Pilchard
OK - no visible damage	108	85	119	27
Damaged	11	26	0	50
Hook left setter with no bait	1	9	1	43

Wear on the painted guide showed the longline sitting in the top corner and entering the setter approximately vertically (Figures 25 – 27).

Video footage recorded most bait loss and damage in the same locations as trip 1G: before the setter (Figures 25 and 26) and at the leg of the setter. However, approximately half the baits passed under the shorter leg, rather than around it.

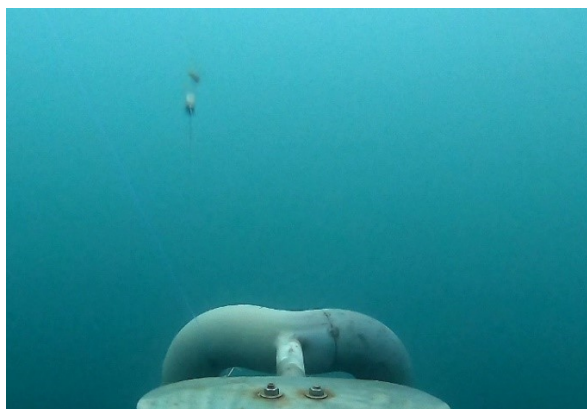

Figure 25. Pilchard bait damage as hook gets pulled forwards into setter – note bait still on the hook and a piece of loose guts above.

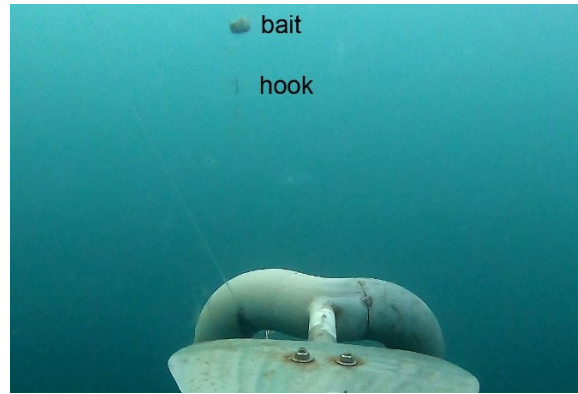

Figure 26. Pilchard bait loss as hook gets pulled forwards into setter.

Droppers consistently passed smoothly through the setter (Figure 11) and at the end of the set the heavier end weight dropped the longline out of the guide successfully, as the brake on the drum was released.

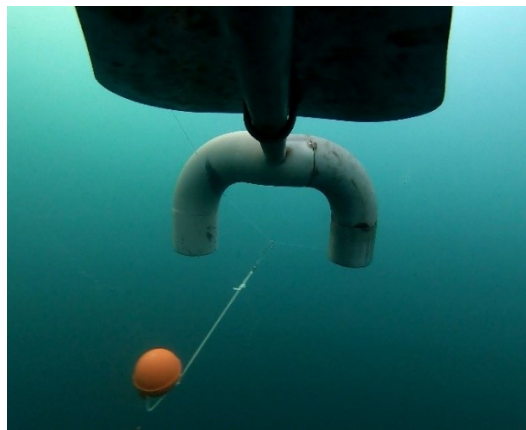

Figure 27. Dropper passing through setter.

Discussion

The setter performed well at 4.9 knots and 5 m depth, noting that 4.9 is the GPS speed over the ground which may have been slightly lower through the water. The shorter legs held the line in the guide, and resulted in less baits contacting the setter and allowed the line to be dropped out by a heavy weight at the end of the set.

Bait retention rates for salted sanma and squid are commercially viable, as is a setting speed of around 5 knots. Pilchard baits are larger and more fragile and use of the setter resulted in unacceptably high bait loss rates. Pilchard baits were lost even before contacting the setter, indicating that pulling these baits down through the water column into the setter can pull them off the hook. The forces exerted on baits will be dependent on the curve of the line between the boat and the setter and minimising this curve warrants further investigation.

Assessment of performance using catch rate data inserts several potential sources of bias, especially when using different bait types. Different baits have different physical characteristics, for example squid is much tougher and harder to pull off a hook than fish bait. Fish bait is oilier, and fishers like to use it for several reasons – it leaves a ‘berley’ trail in the water to attract fish, and it tends to catch a wider variety of species than squid. Fish baits are softer and more prone to loss to bait stealing invertebrates and so are returned less often at the haul. Typically, the fleet will use a mixture of squid and fish though the Kotuku fishes with

all sanma. Bait prices, quota packages, fishing areas, and skipper preference all contribute to choice of bait types and, if two or more species are used, the ratio in which they are employed.

At times catch rates of snapper can be high – approaching a fish every hook for sections of a line and these conditions would provide for better assessment of performance using catch rates. This scenario is also most demanding as to maintain such high catch rates all hooks need to be baited. Conversely, when fish abundance is lower having some hooks with no baits may have less impact, assuming fish would find an adjacent hook which is baited.

Despite the difficulties and bias of using catch rate data, and similarly bait returns at the haul to compare different treatments this data is worth recording and examining as it is relatively easy to collect, it must just be interpreted with caution.

Trip 3G

Trip specific objectives:

Test bait retention for sanma and pilchard baits with two different guide setups.

Set at a deeper depth, closer behind the vessel.

Methods

Further modifications were made to the setter guide, aiming to smooth the passage of snoods, and minimise bait loss. The guide shape was altered to help snoods slip downwards off the side of the guide and an adjustable joint was added to allow variation in the angle between the guide and the paravane (Figure 28). Following on from tests conducted to measure cable length, cable angle and weight on the setter, the weight was increased to a 15 kg lead ball, further below the paravane. Similarly, a limiter was added to the hinge to assist with deployment over the longline (Figure 29).

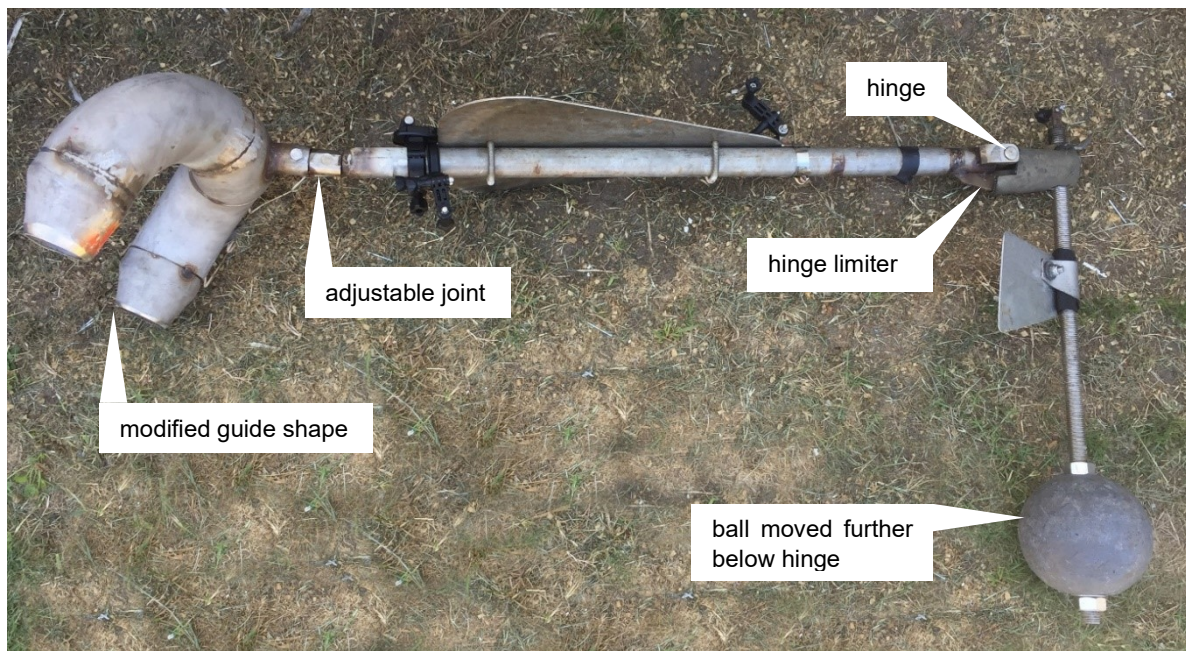

Figure 28. Photograph of the setter showing modifications.

Results

Time depth recorders deployed through the setter indicated that it was running at a depth of eight metres, with 17.5 m of cable deployed, at a setting speed of five knots. This was similar to trials conducted after the set at different cable lengths and speeds (Table 9).

Table 9. Setter depth and different speeds and cable lengths.

Speed (knots)	Cable length (m)	Cable angle (degrees)	Setter depth (m)
5	15	29	7.5
5	20	27	9.8
5	25	23	11.0
6	15	20	5.4
6	20	19	6.9
6	25	20	8.3

A camera beside the setter showed the longline entering the guide at a reasonably consistent 45-degree angle from horizontal. Video from cameras above and below the setter was reviewed to determine the condition of baits and snoods both entering and leaving the setter. Counts indicated that pilchard bait was fragile, and bait loss was unacceptable, both before and after the setter (Table 10). Some bait loss and damage were observed at the back of the boat, and some was not recorded on the camera. Bait loss at the setter occurred in similar locations to previous trips: as baits rapidly changed direction into the setter, or were wrapped around the guide. Some snoods were tangled around the mainline prior to reaching the setter and these tended to result in baits being wrapped around the guide and lost. Video showed some baits spinning as they were pulled towards the setter and this may have contributed to snood tangles. Clips that ran freely on the line and were up against the stoppers as they approached the setter had a smoother passage through the setter and less bait loss.

Increasing the angle at which the guide was swept back improved bait retention by smoothing the passage of snoods, however it also caused clips to be lost (Table 10).

Table 10. Bait and snood condition counts entering and leaving the setter from video footage. Baits were considered damaged if the flesh was torn or partially missing. Baits with some or all of the guts missing were recorded as 'guts missing'.

Guide setup		Straight	Straight	22.5°	22.5°
Bait species		Pilchard	Sanma	Pilchard	Sanma
		percentage of baits			
Bait condition pre setter	Absent	36	5	38	7
	Damaged	3	0	3	5
	Guts missing	5	1	11	0
	OK	57	95	49	91
Snood tangled round mainline		11	5	8	0
Bait condition post setter	OK	6	76	38	82
	OK (pilchard head)	18	0	4	0
	Guts missing	9	3	9	5
	Damaged	6	8	1	0
	Absent	61	14	48	12
Baits lost at setter		20	8	35	5
Snood unclipped		1	2	14	19
n		120	131	120	57

Setting time was later than the skipper's normal set, to provide enough light to reliably use video footage to assess bait loss. Approximately 10-20 flesh-footed shearwaters were following the vessel and landing in the water behind the tori line. They were thought to be chasing scraps of baits/guts lost at the boat as only a single shallow dive was seen.

Discussion

Pilchard bait loss was unacceptable – baits that did stay on were often heads, and these are not commonly used by the fleet. The bait loss prior to reaching the setter seems to be a result of pulling baits down through the water column, rather than laying them into the water as per a normal set. Therefore, as this seems to be unavoidable with underwater setting, it seems prudent to continue trials with sanma baits.

The modifications made to the guide showed promise. A 22.5 degree angle on the joint was chosen as a maximum setting as larger angles did not provide enough depth in the guide to hold the longline during deployment. Smaller angles may still provide a smoother passage for snoods without the loss of clips. Similarly, the skipper uses his own unique clip design which may be more susceptible to being unclipped by the setter compared to the standard 'JVI' clips used by the rest of the snapper fleet (Figure 30). Snoods tangling around the mainline appears to happen more frequently with the setter deeper and closer to the boat, and this is consistent with the results from the setter with wheels, albeit with a different clip design.



Figure 30. Photograph showing JVI clip (top) as used by the majority of the snapper fleet, and the skipper's clip (B's clip) design (bottom).

Trip 4G

Objectives

Reduce clip loss

Measure clip retention for JVI clips

Methods

Changes were made as follows:

The setter was deployed at five knots on 20 m of cable to try and achieve a greater depth.

The set-back angle of the guide was reduced using a joint angle of 12 degrees to decrease clip loss and to see if a shallower angle still allowed baits to pass clear of the setter.

Given the loss of pilchard baits prior to entering the setter it was deemed sensible to progress trials with sanma baits.

Setting time was in line with the skipper's normal pattern – shooting early to reduce risk to birds and to more accurately reflect normal fishing conditions when comparing catches.

A torch was added to illuminate the guide.

JVI clips, as used by the rest of the fleet, were trialled as these were expected to be less prone to coming unclipped than the skipper's clips (Figure 30).

Results

The setter ran at 9.2 m depth.

Without so much ambient light the cameras did not provide for full counts and classification of bait retention and condition. However, the cameras could see snoods consistently passing through the setter and off the bottom of the guide, rather than pulling baits around the guide.

On the section of line deployed the setter, with associated increase in line tension, there was a noticeable difference at the haul with catch rates of snapper dropping and bait returns increasing. Bycatch increased slightly but was represented by small numbers of fish (Table 11).

Approximately half of the JVI clips were lost, though loss of the skipper's clips was in line with that on the normal gear.

Careful examination of the video footage indicated that clipping on the JVI clips upwards, rather than downwards (rotated 180 degrees) would likely increase retention, and this was supported by bench tests ashore.

Discussion

The longer cable allowed the setter to run at a suitable depth.

The marked change in catch when using the setter was alarming (Table 11). However, bait return rates and video footage indicated that baits were present on the longline during the soak. Gear was set in an area where fishing was expected to be consistent, based on previous days' catch. High line tension through the setter, as opposed to low tension setting control gear, seems likely to be the cause of lower catch rates. This could be due to fish being put off by a tight line vibrating in the water. This cause is supported by snapper catch rates dropping off whereas catch rates of more pelagic fish, that are less sensitive and cannot be herded and caught seining (such as kingfish and kahawai), seemed slightly better (Table 11).

Increasing the line tension is also likely to alter how the gear sits on the sea bed, which may influence fishing. However, catching the odd starfish indicates that at least some baits are reaching the sea bed, as would be expected with a dropper length of 1.8m.

Losing a large proportion of the JVI clips was unexpected, however rotating these may solve this loss. Reducing the angle on the joint appeared to reduce clip loss of the skipper's clips to a rate in line with that on the control gear (Table 11).

Trip 5G

Trip objectives

Examine JVI clip retention when clipped on upwards.

Compare catch rates and bait returns between control gear set normally, gear set with high line tension through the setter, and gear set with reduced line tension through the setter.

Methods

No structural changes were made to the setter, however the guide set back angle was further reduced to six degrees. The setter was run at five knots on 20 m of cable, at the end of the set.

Results

The setter ran at eight metres depth.

Using JVI clips the other way around (clipping upwards rather than downwards) resulted in better clip retention (Table 11).

The longline dropped out of the setter at medium line tension after around 150 hooks and the last part of the line was set without the setter. Examination of video footage showed a hook caught around the mainline which formed a loop around the guide, pulling the rear of the setter upwards and the mainline out of the guide.

Poor catch rates and higher bait returns were again experienced on the gear set through setter. Bycatch was slightly higher than on the control gear (Table 3).

The longline angle entering the setter varied from 35-55 degrees at high line tension and 75 to 90 degrees at medium line tension. Video footage showed this angle oscillating (or 'searching'), indicating that the setter was not stable in the water and pitching relative to the water flow.

Discussion

Reversing the direction that the JVI clips were clipped on, and possibly further reducing the joint angle, improved clip retention markedly (Table 11). However, absolute loss rates of clips should be interpreted with caution due to relatively low sample sizes.

Poor catch rates on gear deployed through the setter were again disappointing. In a similar manner to trip four, high bait returns indicated that the high line tension is the contributing factor. Catch rates on control gear set at low tension after the setter were also low (Table 11) indicating that fishing may have been patchy and/or poorer as the line progressed. Equally, due to the stretchiness of the nylon longline, one would expect the effect of high line tension to travel down the line some distance after the tension was reduced.

Although some pitching can be seen on the side camera view, the searching behaviour of the setter is not fully described because cameras are fixed to the setter behind the hinge. Consequently, whether this instability is a result of the setter just pitching, or rolling or yawing as well, is hard to identify. With the lead ball further below the setter than early trips, and the limiter on the hinge, it seems likely that drag on the ball is causing the back of the setter to lift, which is then pushed back downwards by the paravane.

Trip 6G

Trip objectives:

Set the longline with less tension

Run the setter shallower and further behind the vessel to better cope with low line tension

Assess whether less tension allows snoods and floats to pass around setter

Compare catch rates with control gear set normally.

Methods

Changes made included:

The range of the hinge was extended to allow the lead ball to drag backwards without tilting the paravane, in an attempt to reduce the 'searching' behaviour experienced in trip 5, after lowering the ball.

A vent hole was added at the top of the guide to allow the guide to rapidly fill with water on deployment, thereby making it easier to drop the setter on top of the longline and gradually lower it underwater.

A smaller lead ball (12.5kg vs 15kg used previously) was manufactured to reduce the depth of the setter, thereby reducing curvature of the longline entering the setter at low line tension.

Line tension was reduced in a stepwise manner for gear set through the setter, finishing at normal line tension, similar to that used for the control gear.

Results

The setter ran at 8.7 m depth initially and then reduced to 8.2 m at lower tension. Deployment was easier with the vent hole allowing the setter to sink quicker. Once below the boat, in clean water, the setter was stable and the guide held the line well. Setting speed was slightly slower than earlier trips, (4-4.5 knots compared to 5 knots) due to limited line left and wanting to fit all the gear on it.

The angle of the longline entering the setter varied from 45 degrees initially up to 90 degrees at the lowest ('normal') line tension. Clips and snoods behaved similarly to previous sets, despite the line entering the setter from directly above at low tension (Figure 31). Clip loss was lower than previous trips and approaching the control gear, though again, sample sizes are small (Table 11).

Bait returns and, more importantly snapper catch rates for gear set through the setter compared favourably with the control gear (Table 3). Lower line tension allowed the line to drop out of the setter when the heavier end weight was attached, making the recovery of the setter easier.

Discussion

The changes made to allow the setter to operate with lower line tension appeared to result in catch rates similar to the control gear, at the expense of operating at a shallower depth (eight metres).

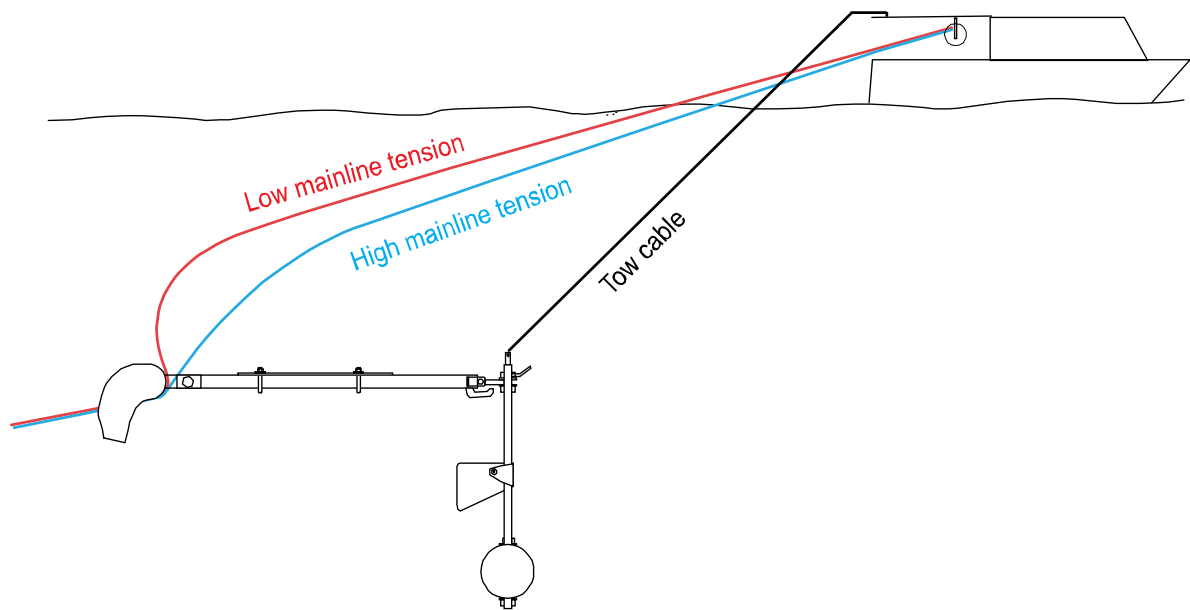

Figure 31. Schematic diagram showing curvature in mainline at different line tensions.

Trip 7G

Trip objectives

Run gear through the setter at low line tension and slightly faster speeds than previous trips, and compare catch rates between gear set normally and gear set through the setter.

Methods

No changes were made to the setter.

The longline was deployed at the same tension throughout the set within the range used during normal fishing. The setter was deployed half way through the set and was towed at 5.4 knots on 20 m of cable.

Catch was recorded in sections between surface floats for the control gear and in sections between weights for the setter gear. This allowed catch records to be aligned with whether the line was in the setter, in combination with hook counts on the video. Clip loss and bait retention was grouped from the control gear.

Results

The setter initially ran at 5.7 m depth with a cable angle of 18 degrees. The setter dropped the line on the seventh dropper, after 210 hooks, due to the weight pulling the longline out of the bottom of the guide. Without the longline in, the setter ran at 5.5 m on 20 m of cable and 7.0 m with 25 m of cable, with a cable angle of 16 degrees. The longline entered the setter at a reasonably consistent 40-45 degrees.

Catches were patchy, which meant no firm conclusions could be drawn regarding the effect of using the setter (Table 4). Ten clips were lost in the second half of the gear but these were not attributed to a treatment. Baits appeared to be passing consistently beside the guide.

Discussion

With lower line tension when weights are clipped on the curvature of the line running into the setter was taken out and the line had sufficient slack to be pulled downwards out of the setter guide.

Lower line tension and more movement in the hinge than earlier trips resulted in less load on the paravane. In turn, this has caused the setter to run shallower, because the paravane was not providing so much downward force. This is supported by the small change in depth when the setter dropped the line, indicating that the line does not cause the setter to dive markedly deeper. Reduced loads on the paravane resulted in the setter being more stable, but indicate that depth needs to be achieved by weight rather than force on the paravane.

Trip 8G

Trip objectives

Run hooks through the setter with similar line tension to normal fishing, slightly deeper and slightly faster than trip 7.

Methods

The lead ball was swapped, increasing the weight from 12.5 kg to 15 kg. The setter was run at 4.8-5.1 knots on 20 m of cable. Tension was low during the control gear, and slightly higher, but within the skipper's normal fishing range, for gear set through the setter.

Results

The setter ran at a depth of 7.8 m at 5.2 knots, then the line came out on the second dropper, after 60 hooks. The dropper was sinking behind the setter and as the float was pulled forwards around the setter guide, the line was forced downwards off the bottom of the guide. As the float was pulled forwards the guide was pulled upwards by the float, allowing the line to drop out (Figure 32).

The setter was re-deployed and ran at 9 m depth at 4.8 knots, and 8.5 m depth at 5 knots, both on 20 m of cable. After 210 hooks a snood entered the setter tangled around the mainline and a loop formed around the guide, lifting the guide upwards and allowing the line to be pulled out of the guide (Figure 31).

The longline was entering the setter at a reasonably consistent angle of 73-79 degrees.

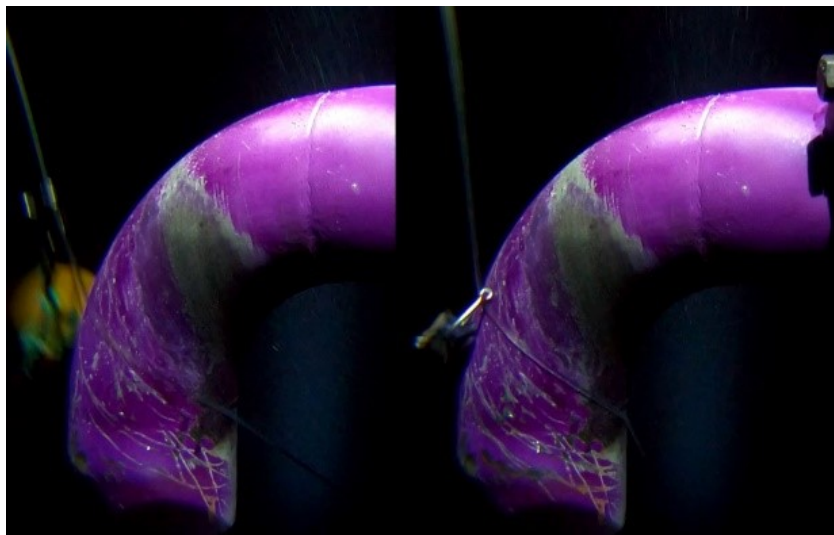

Figure 32. Composite photograph showing float (left) and tangled snood (right) causing the setter to lose the longline. The grey section of guide without purple paint shows normal position of longline.

Catch rates were again patchy providing little information on setter performance (Table 12). Baits were consistently passing beside the guide but some damage and loss of guts was visible on the video, greater than that seen in trips 6 and 7.

Discussion

Deploying gear through the setter at low line tension is more challenging and requires finer adjustment of settings in order to balance the forces acting on the setter and the longline (Figure 33).

At lower tension, higher speeds, and deeper depths, the longline enters the setter at steeper angles, resulting in more force on baits as they are pulled downwards towards the setter, and forwards and down beside the setter.

Increasing the leverage of the paravane, by moving it closer to the guide, may help keep the setter level and keep the longline in the guide and reduce line drop outs.

Ensuring that clips match the diameter of the longline and can swivel freely will reduce the frequency of snoods tangling around the mainline prior to entering the setter.

Unwinding dropper weights before clipping them on may help them to sink quicker, in front of the setter.

In the event of a hook catchup around the mainline the setter tipped up and the line was pulled out of the guide, allowing the set to continue. However, it may be preferable to break the snood and continue to set underwater.

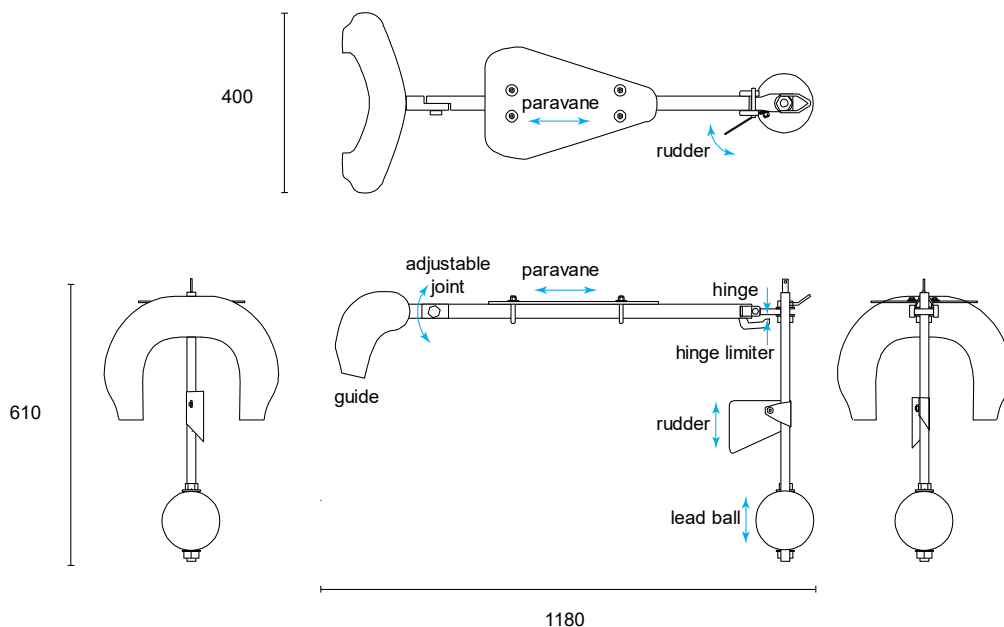

Figure 33. Schematic diagram showing setter after trip eight. Adjustable components are labelled with blue arrows indicating direction of adjustment.

The adjustable joint alters the set-back angle of the guide. A larger set back angle provides for a smoother passage for snoods allowing them to peel off the bottom of the guide earlier. A smaller set back angle, and more upright guide, holds the longline in the guide more securely and is less vulnerable to dropping the longline.

The paravane can be moved along the tube to increase or decrease the leverage and downwards force on the guide.

The angle of attack and height of the rudder can be varied to steer the front of the setter and counteract the rolling force applied by the line running off centre through the guide.

The height of the lead ball alters the righting moment to control roll. The ball tends to drag backwards under the setter and will cause the rear of the setter to lift, which in turn causes the paravane to provide a downwards force.

The clearance at the hinge limiter controls the angle the ball can drag backwards under the paravane before it tips the rear of the setter upwards. It also acts to stop the rear of the setter folding downwards during deployment.

Table 11. Fish catch and bait returns for lines set with and without the setter, during trips four, five and six. Species codes as follows: SNA = snapper, KIN = kingfish, TAR = tarakihi, GUR = gurnard, TRE = trevally, KAH = kahawai, BCO = blue cod, FRO = frofish, WHE = whelk, POP = porcupine fish, SFI = starfish, OSE = snake eel, CAR = carpet shark

Trip 4			Per 100 hooks																
Treatment	Line tension	Speed	Fish catch												lost clips	whole baits	partial baits	n	
			SNA	KIN	TAR	GUR	TRE	KAH	BCO	FRO	POP	SFI	OSE	CAR					
Control	low	5	17.4	0.0	0.2	0.0	0.0	0.0	0.0	0.0	0.0	0.2	0.5	0.0	0.0	0.5	0.5	6.0	420
Setter JVI clips	high	5	0.0	0.0	0.0	0.0	0.0	0.0	0.8	0.0	0.0	0.0	0.0	0.0	0.0	25.8	25.8	5.8	180
Setter B's clips	high	5	7.5	0.8	0.0	0.0	0.0	0.0	0.2	0.0	0.2	0.0	0.4	0.2	0.2	0.4			480
Trip 5			Per 100 hooks																
Treatment	Line tension	Speed	Fish catch												lost clips	whole baits	partial baits	n	
			SNA	KIN	TAR	GUR	TRE	KAH	BCO	FRO	POP	SFI	OSE	CAR					
Control	low	5	39.3	0.0	0.0	0.7	0.1	0.2	0.1	0.0	0.0	0.0	0.4	0.3	0.0	0.5	5.8	3.4	1105
Setter JVI clips	high	2-4	11.7	0.0	0.0	0.0	0.0	0.0	0.0	0.0	0.0	0.0	3.3	0.0	0.0	1.7	26.7	5.0	60
Setter B's clips	high	4	14.4	1.7	0.0	1.1	0.0	3.3	0.0	0.0	0.0	0.0	0.0	0.0	0.0	1.7	40.0	5.6	180
Setter JVI clips	med	4	10.0	0.0	0.0	0.0	0.0	0.0	0.0	0.0	0.0	0.0	0.0	0.0	0.0	6.7	33.3	10.0	60
Setter B's clips	med	4	10.0	0.0	0.0	1.7	0.0	0.0	0.0	0.0	0.0	0.0	0.0	0.0	0.0	3.3	41.7	8.3	60
Control	med*	5	2.5	0.0	0.0	0.8	0.0	0.0	0.0	0.0	0.0	0.0	2.5	0.0	0.0	0.0	37.5	10.0	120
Trip 6			Per 100 hooks																
Treatment	Line tension	Speed	Fish catch												lost clips	whole baits	partial baits	n	
			SNA	KIN	TAR	GUR	TRE	KAH	BCO	FRO	POP	SFI	OSE	WHE					
Control	low	5	17.3	0.2	0.0	0.6	0.0	0.0	0.0	0.2	0.0	0.0	2.1	1.5	0.2	0.4	26.7	6.9	480
Setter	med-low	4	15.8	0.0	0.0	0.3	0.0	0.0	0.0	0.0	0.0	0.0	1.0	0.0	0.0	1.3	18.8	3.4	298
Setter	low	4	20.6	0.0	0.0	1.7	0.0	0.0	0.0	0.0	0.0	0.0	1.7	0.0	0.6	1.1	42.8	11.1	180

Table 12. Fish catch and bait returns for lines set with and without the setter, during trips seven and eight. Species codes as follows: SNA = snapper, KIN = kingfish, TAR = tarakihi, GUR = gurnard, TRE = trevally, KAH = kahawai, BCO = blue cod, EMA = blue mackerel, WHE = whelk, POP = porcupine fish, SFI = starfish, OSE = snake eel, EGR = eagle ray. *One clip was lost during trip 8 but not attributed to a treatment.

Trip 7			Per 100 hooks																
Treatment	Line tension	Speed	Fish catch													lost clips	whole baits	partial baits	n
			SNA	KIN	TAR	GUR	TRE	KAH	BCO	EMA	POP	SFI	OSE	EGR					
Control	low	5.5	25.0	0.0	0.0	1.0	0.0	0.7	0.0	0.3	0.0	0.0	0.0	0.0	0.3	0.0	7.0	5.7	300
Control	low	5.5	24.0	0.0	0.0	0.7	0.3	0.0	0.0	0.0	0.0	0.0	0.0	0.0	0.0	0.0			300
Setter	low	5.5	15.0	0.0	0.6	0.6	0.0	0.6	0.6	0.0	0.6	0.0	0.0	0.0	0.0	0.0	16.1	7.2	180
Control	low	5.5	11.7	0.0	0.0	1.2	0.0	0.5	0.0	0.0	0.2	0.5	1.2	0.0	0.0	0.0	26.0	7.6	420
Trip 8			Per 100 hooks																
Treatment	Line tension	Speed	Fish catch													lost clips*	whole baits	partial baits	n
			SNA	KIN	TAR	GUR	TRE	KAH	BCO	WHE	POP	SFI	OSE	EGR					
Control	low	5.2	26.0	0.0	0.3	1.0	0.0	0.3	0.0	0.0	0.0	0.0	0.0	0.3	0.0	0.0			300
Control	low	5.2	33.7	0.3	0.0	0.0	0.0	0.0	0.0	0.0	0.0	0.0	0.0	0.3	0.3	0.0	10.5	9.0	300
Control	low	5.2	16.7	0.0	0.0	1.9	0.0	0.0	0.0	0.0	0.0	1.4	1.9	0.0	0.0	0.0			360
Control	low	5.2	11.3	0.4	0.0	0.8	0.0	0.0	0.0	0.4	0.4	5.0	0.4	0.0	0.0	0.0			240
Setter	low+	4.8	21.7	0.0	1.7	0.0	0.0	0.0	0.0	0.0	0.0	0.0	0.0	0.0	0.0	0.0	10.0	6.7	60
Control	low	4.8	15.6	0.0	0.0	1.1	0.0	0.0	0.0	1.1	0.0	2.2	0.0	0.0	0.0	0.0	13.3	6.7	90
Setter	low+	4.8-5.1	19.5	0.0	0.0	1.4	0.5	0.0	0.0	0.0	0.0	0.0	0.5	0.0	0.0	0.0	5.7	2.4	210
Control	low	5.1	24.0	0.0	0.0	0.0	0.0	0.0	0.0	0.0	0.0	0.7	0.0	0.0	0.0	0.0	2.7	4.7	150