

Ohau Snow Holdings
Chairlift Application:
Additional Information
for Concession Variation
Application 2018-19



Prepared by Rob Young, Te Manahuna Consulting,
February 2019 for OSHL



Contents

Ohau Snow Holdings Chairlift Application: Additional Information	2
Introduction	2
Engineering, design and construction works	2
Drive terminal and return terminal – including construction and footprint	2
Total chairlift footprint.....	2
Chair base facility	2
Return terminal.....	3
Tower construction.....	4
Access track and access to the lift both for construction and operation	4
Access track.....	4
Access for construction.....	4
Operational access.....	4
Ecological assessment.....	5
Previous surveys	5
Threatened plant list 2017.....	5
Botanical survey of the plant communities at each structure site	5
Fauna.....	16
Other natural features	16
Further development as a result of the increased skier capacity.....	17
Projected skier capacity increase.....	17
Strategies to avoid, minimise or remedy any adverse effects - including cumulative effects, identified.....	18
Construction.....	18
Operational	18
Appendix 1: Email extract from DOC re additional information required.....	19
Appendix 2: Ecological Report 2012	20
Appendix 3: Engineering Drawings	23
Bibliography	30

Cover photo: Top of the ridge near the proposed return terminal. (R. Young).

Ohau Snow Holdings Chairlift Application: Additional Information

Introduction

This report provides additional information for the original chairlift application made on the 19 November 2018. This additional information was requested on the 21 January 2019, and the key additional information requested is outlined in Appendix 1.

Engineering, design and construction works

The recycled chair which is being used for this project was originally sited at Cardrona. It was purchased by OSHL in 2013. The chair is absolutely fit for purpose for its proposed new use and fits with the sustainable future philosophy of OSHL in that it is being recycled, will be powered with renewable energy (hydro generated electricity) and will give the area a sustainable future in years of slim snowfall.

The chair has recently undergone re-engineering design to make it compliant with new New Zealand chairlift standards. An experienced American lift designer who specialises in second hand lifts was brought out to New Zealand to complete this work. The planning and design of the lift line, footings and foundations is being undertaken by Tim Dennis of Southern Land and Lewis and Barrow.

Grant Horner, the former Chief Executive of Doppelmayr NZ, has been employed to provide advice and oversee the actual lift construction.

The excavation and earthworks will be undertaken by Recreation Construction Ltd. who specialise in recreation construction work and have undertaken such work in sensitive areas including three national parks, Arthurs Pass, Aoraki Mount Cook and Aspiring.

The concrete, towers, other steel and building materials for the chairlift will be flown from the base area of the new chair to each site by helicopter. These materials can be taken to this site by way of the current access tracks and ski trails.

Drive terminal and return terminal – including construction and footprint

Total chairlift footprint

The total licence area for the OSHL is 145.2ha. The total disturbance area for all the structures for this new chairlift is less than a 1000m² (0.1ha), about 0.07 percent of the total licence area. The footprint area of the structures, when the terrain around the structures is restored, will be around 250m² or 0.02 per cent of the total licence area.

Chair base facility

The drive terminal and base facility will be constructed in a similar style as the existing chair. There will be four concrete footings, placed 2.1m deep which will be backfilled and landscaped to existing ground level. The excavation of the footings will be undertaken with a 1.8 tonne digger. The outside dimensions of the footings area will be 12 x 12m. Steel towers will be bolted to the footings and the drive station building constructed on a platform on top of these towers. The finished dimensions of the four towers will be 8.25 x 8.25m. The lift operators' shelter will be constructed under the platform and between two of the towers. The towers and buildings will be painted in the current colour scheme (Figure 1). The attached engineering drawings (Appendix 3: Engineering Drawings) provide the detail on this facility. The finished height of the drive terminal will be 6.8m.



Figure 1: Existing drive station and base building.

Return terminal

The return terminal will also be similar in design to the existing return terminal. There will be one footing for this return with the dimensions of 4.5 x 5.5m and 1.0-1.5m deep. Again, the footing will be excavated and backfilled and the area around the footing landscaped into the existing terrain at the ridge line, including a sloping offloading ramp. The excavator will be flown in and out of this site.

A small, but suitably engineered top lift station hut (<10m²) will be constructed in the vicinity of the return terminal for the lift operator and ski patrol. This building will be like the existing “top shack” on the existing chairlift (see Figure 2).



Figure 2: Existing return terminal and “Top Shack”.

Tower construction

Recreation Construction will use the small 1.8 tonne excavator and if necessary, explosives for all the footing work. The excavator and other equipment can be brought to the base terminal area and the first three towers by way of existing ski trails and the formation of a narrow 1.0m wide access track from the new base station to these three towers avoiding sites with vegetation. This new track will be reinstated after the works are completed.

For the other six towers the excavator will be flown by helicopter to each site. A small 2x2m flat platform will be constructed by hand to land the excavator on so it can be set up safely at each tower site. This will minimise the disturbance at each site and ensure the work is undertaken with the greatest care possible in this licence area within the Ahuriri Conservation Park. The excavator will work from one side and bottom side of the footing excavation.

The concrete base footings vary in size up to 4 x 3.5m. The excavated material will be placed within a limited area around the footing hole. This material will be used to backfill the footing excavation and the area around the footing reinstated to as near to the original ground contour when the work is completed.

Access track and access to the lift both for construction and operation

Access track

The access track proposed in the original application has now been discarded. This is a result of the further on-site survey work, the landscape impact and cost of both establishing this track and the ongoing maintenance in summer and winter.

Access for construction

The access for construction will be via existing tracks to the base of the new chairlift, then helicopter for materials and equipment and walking the line to each tower site from the base when a helicopter is not required for construction purposes. The helicopter will be required for every stage of construction including the excavation (transport of excavator etc), foundation concrete and erection of the towers.

Operational access

For operational access to the top of the lift, OSHL is going to purchase a skidoo which can go to the ridge from the existing chairlift terminal and then around the ridge to the top of the new chair. This will avoid any physical impact of constructing a permanent access track across the back bowl as originally proposed.

Ecological assessment

Previous surveys

The area was assessed during the 1984 PNAP survey, (Espie & et al., 1984). Two sites were identified in neighbouring areas of the Maitland Valley and Lake Dumbell, but nothing close to this site on this side of the Ohau Range. As noted in the original application for this chairlift the area was surveyed botanically in 2012 by the renowned botanist, Neill Simpson.

Threatened plant list 2017

The complete range of native plants found at the site have been reviewed against the updated threatened plant list. (de Lange & et al., 2017). There are no plants which were found in the original survey or in the more recent survey of each of the structure sites which are classified as threatened.

Botanical survey of the plant communities at each structure site

On the 6 February 2019, a botanical survey of the structure sites was undertaken by Rob Young. Rob has a BSc. (Botany) and has undertaken extensive botanical survey work early in his career with the NZFS as well as maintaining a continued interest in botanical matters during his 34-year career in the National Park Service and DOC.

This recent botanical survey focused on the actual structure sites. This follows on from the wider ecological survey undertaken in 2012 (Simpson, 2012).

As noted earlier the total disturbance area for all the structures for this new chairlift is less than a 1000m² (0.1ha), and the botanical survey included this “disturbance zone” at each structure site. The total area of vegetation which will be removed or disturbed across all sites is calculated to be less than 150m² in total.

The results of the survey and the plants found at each site along with an estimate of the percentage cover of vegetation at each site is described in Table 1: “Plant Species at Ohau Chairlift Structure Sites”. Photos of each site have been provided along with an estimate of the approximate disturbance area at each site. While, some further 15 species were found during this survey which were not noted in the earlier survey by Neil Simpson this is a result of the different timing and conditions at the time of each survey.

There are eleven structure sites in total, being the base drive station, top return station and the 9 towers. A total of 33 native species were sighted during the recent survey. Twenty-two of the native species were found at two or more sites and of the eleven species found at only one site, all but three were seen outside of the structure sites. These three species were single plants, *Melicytus alpinus*, *Carex wakatipu* and *Veronica pinguifolia*.

Table 1: PLANT SPECIES AT OHAU CHAIRLIFT STRUCTURE SITES

		BASE	T1	T2	T3	T4	T5	T6	T7	T8	T9	TOP
		DRIVE										RETURN
Altitude (masl)		1679	1690	1720	1734	1774	1815	1857	1890	1925	1951	1954
Plant cover %		10	40	50	0	0	25	20	<5	0	<5	<5
STATUS		17	19	18	0	0	20	15	3	0	10	1
SPECIES												
Acaena saccatipula	NT		x									
Aciphylla dobsonii	NT	x	x	x			x	x	x		x	x
Aciphylla monroi	NT						x					
Agrostis capillaris	NA	x										
Anisotome flexuosa	NT	x	x	x			x	x				
Blechnum spp. penna marina	NT	x	x	x			x				x	
Celmisia hectorii	NT		x						x		x	
Celmisia laricifolia	NT	x										
Celmisia lyallii	NT		x	x			x	x				
Celmisia sessiflora	NT	x		x			x	x			x	
Celmisia walkerii	NT						x	x				
Chionchloa macra	NT	x	x	x			x	x	x			
Colbanthus acicularis	NT										x	
Dracophllum muscoides	NT	x						x				
Dracophyllum pronum	NT		x	x			x	x				
Epilobium porphyrium	NT		x	x			x					
Euphrasia zealandica	NT	x										
Gautheria depressa var. novae z.	NT	x	x	x								

Table 1: (continued).

		BASE DRIVE	T1	T2	T3	T4	T5	T6	T7	T8	T9	TOP RETURN
Altitude (masl)		1679	1690	1720	1734	1774	1815	1857	1890	1925	1951	1954
Plant cover %		10	40	50	0	0	25	20	<5	0	<5	<5
No. of species		17	20	18	0	0	19	14	3	0	10	1
SPECIES	STATUS											
Gentianella corymbifera	NT						X	X			X	
Kelleria diffenbachii	NT	X	X	X								
Leptinella pectinata subsp. vilosa	NT						X					
Leucogenes grandiceps	NT		X	X			X				X	
Luzula pumila	NT						X	X			X	
Melicytus alpinus	NT			X								
Phyllachne colensoi	NT	X					X	X				
Pilosella officinarum	NA	X	X									
Pimelia oreophila	NT	X	X	X								
Poa colensoi	NT	X	X	X			X	X			X	
Polystichum cystostegium	NT		X	X			X					
Rumex acetosella	NA	X	X	X								
Rytidosperma pumilum	NT		X									
Sclerantus uniflorus	NT			X								
Veronica pinguifolia	NT										X	
Veronica pulvinaris	NT						X	X				
Wahlenbergia albomarginata	NT	X	X	X			X	X				

Drive Terminal and Base Station

The base site has a vegetation cover of approximately 10 per cent with 17 plant species present. The most dominant plant is *Dracophllum pronum*. Around 80 per cent of the site is already modified by the Sun Run trail works which were completed many years ago.

The construction of the drive terminal will not disturb the small wetland below the site which was noted in the 2012 ecological report, (Simpson, 2012).



Figure 3: Base area – tape around the area of the disturbance.



Figure 4: Base area – mostly modified ground.

Return Terminal

The return terminal which is on the top of the ridge below peak 1980m is relatively barren site, covered in small to medium scree with a few scattered *Aciphylla dobsonii* plants, within or close to the area that is part of the footprint and disturbance area of the structure. The rock and scree in this location shows signs of patterned ground due to repeated freezing and thawing cycles.



Figure 5: Top return terminal area – Tower 9 is just over lip.



Figure 6: Top terminal return area – lift comes up from the right. Peak 1980m in background.



Figure 7: Lift line from base area to the ridge

Tower sites

Three of the tower sites (see Figure 10: Tower 3, Figure 11: Tower 4, Figure 15: Tower 8), have no vegetation within the area of the foundations or the area which will be disturbed or modified during construction. The surface is either medium size to large rock and scree. A further two sites (see Figure 14: Tower 7, Figure 16: Tower 9), have less than 5 per cent vegetation cover with similar type of scree cover over the rest of the site.

The remaining four tower sites (see Figure 8: Tower 1 (at pink peg) , Figure 9: Tower 2, Figure 12: Tower 5, Figure 13: Tower 6), have vegetation cover ranging from 20-50 per cent and between 15 and 20 different species at each site.



Figure 8: Tower 1 (at pink peg) - 40% vegetation cover.



Figure 9: Tower 2 – 50% vegetation cover.



Figure 10: Tower 3 - 0% vegetation cover.



Figure 11: Tower 4 - 0% vegetation cover.



Figure 12: Tower 5 - 25% vegetation cover.



Figure 13: Tower 6 - 20% vegetation cover.



Figure 14: Tower 7 - < 5% vegetation cover.



Figure 15: Tower 8 - 0% vegetation cover.



Figure 16: Tower 9 - < 5% vegetation cover.

Fauna

The Ohau Snowfields environment at the altitude of this lift does not have a rich fauna associated with it, which is typical of these environments in these ranges east of the Main Divide. During the recent botanical survey of the structure sites, fauna observations were made during the day, both on the chairlift line and in the vicinity of the line.

Invertebrates, including several different alpine grasshoppers and black ringlet butterflies (*Percnodaimon merula*), were observed during the warmer part of the day. Alpine scree weta, (*Deinacrida connectens*), have been sighted at Ohau previously, but none were seen on the 6 February 2019. The endemic weevil (*Lyperrobius spp.*) is likely to be present on the host plant, *Aciphylla dobsonii*. A more thorough survey would undoubtedly reveal more invertebrate fauna.

No lizards or birds were sighted while in the vicinity of the proposed lift line. Lizard fauna is unlikely to be abundant or present in this higher altitude scree environment, (Pers. comms. D. Nelson, DOC). Bird species noted in the Ohau Snowfields area on other visits have included NZ pipit or pīhoihoi, (*Anthus novaeseelandiae*), and Chukor, (*Alectoris chukar*). NZ falcon or karearea, (*Falco novaeseelandiae*) are often seen at lower altitudes. Kea, (*Nestor notabilis*) while present in areas to the north like the Temple Valleys, have not been sighted in the area recently.

A pill beetle, (*Byrrhidae genus*), has been previously found at a restricted site above the pump station site, which is about 300m to the north of the line of the new chair. This site will not be affected by the chairlift construction. This beetle was noted when the snowmaking was originally being constructed and an entomologist visited and reported on it at the time, (Nelson & Nunn, 2008).

Thar, chamois and hares have been seen in the area in summer and winter.

Given the small area affected by the chairlift construction (less than 0.1ha), it is highly unlikely that there will be any significant impact or adverse effects on the fauna in the area. While the proposed works may impact on the habitat of the grasshoppers the scale of this impact in terms of the overall area will be minor, and no doubt they will hop out of the way!

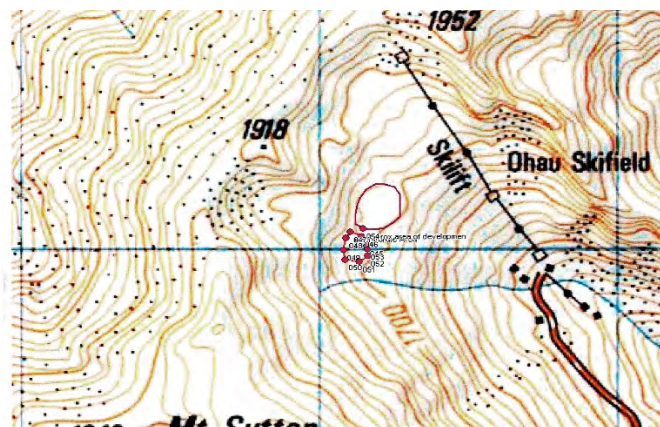

Figure 17: Beetle site (series of red dots). Lift is at bottom of map.

Other natural features

There are no streams or wetlands within the area of the proposed chairlift. A piece of ice from a rock glacier was exposed during the construction of the reservoir in 2008, but there is no evidence of any rock glaciers on the site of the proposed chair.

Further development as a result of the increased skier capacity.

Projected skier capacity increase

Currently the average skier days per winter season are around 16,000 – 17,000. The proposal for this lift has been based on a 1000 skier day increase over the winter season of 100 operating days. This increase will not have a significant impact on the capacity of the other facilities when averaged across the whole season – it equates to 10 skiers increase per day. While it is more likely that this skier increase will occur on say 25 per cent of the open days this still only equates to 40 additional skiers on those days.

Currently, a big day at Ohau is in the vicinity of 400-500 skiers. The facilities currently cope with this level of use, on a fine day. Lift queues only occur on large volume days and are never more than 5 – 10 minutes wait time. The new chairlift will only reduce this likelihood of lift queues as skiers will be spread between the two main lifts. Crowding does occur in the café at times on a high volume day but this proposed capacity increase is unlikely to make a significant difference to the café other than at peak lunch hour as at any time 75 per cent of the clients are out skiing or snowboarding.

Carparking, on high volume days generally fills the existing carparks but it is always managed on these days by having a carpark attendant present to ensure the parks are utilised efficiently and when the road is unsuitable for campervans because of conditions not allowing them up the road and providing bus transport. Bus transport is provided from the lodge every open day so this also reduces the demand for car parks and is another tool that can be used for managing this demand on high volume days.

Further growth in the skier capacity is likely in the future given the growth in the skier market and growth in Twizel and as pressure from Wanaka skiers increases (as a result of capacity issues at the southern fields).

Plans have previously been discussed by OSHL with the Department (prior to 2013 when regular biannual meetings were held), regarding both modernising and increasing the capacity of the base facilities and the carparking. These developments to the base area were noted in writing in the 2000 concession application and in a 2008 file note, (Young, 2008). These included replacement of the older parts of the base building and expanding the café. Currently, these developments are still part of the long term plan.

Future base facility improvements will include increasing the capacity of the café and providing new toilets, ski patrol and rental accommodation. However, none of these improvements will significantly increase the base facility impact as the area where it would be expanded to has already been modified.

Likewise, there is already a further area available for carparking which was where the snow groomer shed, and workshop was previously located. Making this area available for carparking involves some minor work to make the existing area easily accessible to vehicles and it will provide up to a further 40 carparks if required in the future.

Strategies to avoid, minimise or remedy any adverse effects - including cumulative effects, identified.

Many of these strategies have been outlined in each respective section. In summary they are:

Construction

- Sourcing the best technical advice on lift construction in New Zealand
- On site advice from Te Manahuna Consulting regarding managing impacts and effects.
- Use of highly experienced “sensitive site” contractor.
- Use of a small 1.8 tonne excavator.
- Use of a helicopter to provide transport of equipment and materials for all the structure sites, other than for positioning the excavator for the base facility and lower three towers.
- Landscaping and recontouring the sites after construction.
- No permanent tracks or new ski trails to be established for access or skiing.
- Keeping the disturbance to a confined area around each site and only removing or disturbing vegetation where necessary.
- Removal of all rubbish and extra materials following construction.
- Painting the finished structures in the standard colours used at Ohau.

Operational

- Electric powered drive station providing minimal noise and disturbance both on site and more remotely.
- Use of renewable hydro-electricity.
- Increase the higher terrain available for slim snow years as the effects of climate change continue to manifest themselves.
- Provide a wider range of “off piste” skiing for the Ohau clientele.
- Increased skier use of this terrain will stabilise the snowpack in the areas accessible from the lift reducing the need for the use of the avalauncher and the number of explosives used for avalanche control.
- Provide easier on foot access to the “slack country” for ski touring and increase the use of the Ahuriri Conservation Park and surrounding areas in winter.

Appendix 1: Email extract from DOC re additional information required.

The following information is required to enable us to continue processing the Ohau Ski Area application:

1. Information in regard to the nature and extent of any chair base buildings or top of chair stations – including construction and footprint;
2. Further detail around the construction of the access track including associated works, disturbance and mapping;
3. An updated ecological assessment – including assessment:
 - a. against the updated threatened plant list;
 - b. of the sites specific to where the structures (towers and any chair top and base buildings) and roading/access is proposed;
 - c. of any fauna (including lizards, invertebrates and birds) values or impacts.
4. Indication of any further development as the result of the increased skier capacity – e.g. base building improvements, expansion of carpark facilities etc;
5. Any strategies to avoid, minimise or remedy any adverse effects - including cumulative effects, identified.

Appendix 2: Ecological Report 2012

OHAU SNOW FIELDS

ECOLOGICAL REPORT on the PROPOSED NEW CHAIRLIFT in the UPPER BASIN

INTRODUCTION

The Ohau Ski Field is proposing to install a new chairlift to open up a considerable area of the upper slopes for skiing and snowboarding an area presently only accessible in winter by climbing on foot or skinning on skis.

An initial inspection/survey was made of the chairlift line and adjacent slopes on 12th June 2012. There was a thin cover of snow in places but the lift line was largely clear of snow allowing a reasonable assessment of the vegetation growing here and likely to be affected by the installation of a chairlift..

TOPOGRAPHY

The lift line starts on an upper shelf at about 1730 m and slightly downhill and several hundred metres south of the top of the main chairlift terminal. The proposed new chairlift runs steeply, straight uphill passing through a line of small rocky knobs and then to the ridge top at about 1880 m.

The whole slope is composed primarily of medium to large, angular blocks of undifferentiated greywacke. Occasional patches of finer material allow the small patches of vegetation to survive and grow. To the immediate north of the top of the proposed new lift a steep, narrow basin descends to easier slopes at the base of the lift. Further north is a larger, more symmetrical basin that extends from the ridge top down towards the water reservoir and main chairlift. To the south extensive steep rocky slopes drop down to easier slopes at roughly the level of the proposed new lift base before continuing steeply to the skifield base area and road end. These latter slopes are east and north facing.

VEGETATION

Although the snow and the time of year did not allow for a complete survey of the vegetation with some small herbs already "hibernating" underground, there was enough visible to obtain a good idea of the plants and plant communities of this area. This was supplemented by knowledge gained from previous visits to this area.

The whole area from the proposed new lift base to the ridge top has very sparse vegetation. Plant communities and individual plants are mainly confined to the small pockets of finer material that collects where the slope eases slightly or around some larger rocks or on small seepage areas.

Occasional small patches of slim leaved snow tussock (*Chionochloa macra*) occur on or near the proposed lift line. Blue tussock (*Poa colensoi*) and the tiny alpine grass *Rytidosperma pumilum* are part of this community together with a few small herbs.

Around some of the larger rocks a number of small shrubs and herbs grow, all common and typical of these alpine rock areas. All are low growing or form cushions. They include snowberry (*Gaultheria depressa* var. *novae-zelandiae*), *Dracophyllum pronum*, *Dracophyllum muscoides*, *Pimelea oreophylla*, *Kellaria dieffenbachia*, *Stellaria gracilentia*, the small alpine daisies *Celmisia laricifolia* and *Celmisia sessisiliiflora*, a tiny rush *Carex pumila*, the alpine cushion *Phyllachne colensoi*, *Anisotome flexuosa*, a harebell (*Wahlenbergia albomarginata*), orange cushions of *Scleranthus uniflora*, a fern *Blechnum penna marina*, *Leptinella pectinata* and a bidibidi (*Acaena saccaticupula*). Large clumped rosettes of the cushion speargrass *Aciphylla dobsonii* are scattered amongst the rocks

The exotic sheep's sorrel (*Rumex acetosella*) is widespread and small patches of mouse-ear hawkweed (*Pilosella officinarum*) and the exotic grass brown top (*Agrostis capillaris*) occur.

Just below the proposed base station a small wetland or flush contains a patch of a wetland community with comb sedge (*Oreobolus pectinatus*), marsh marigold (*Psychrophylla obtusa*), *Collobanthus strictus*, a tiny cress (*Cardamins* sp.), mosses and a few tiny herbs, sedges and grasses not identifiable at this time of the year.

No plants were seen that are listed on the Threatened and Uncommon plants of New Zealand (2008 revision) (de Lange et al. 2009). At this altitude and with the coarse, rocky nature of the regolith and vegetation seen on this and on past surveys I consider that it is unlikely that plants listed as threatened will be found growing along the proposed lift line but this can only be confirmed conclusively by surveying in the summer when snow is not present and the small plants (grasses, sedges etc) are in flower.

On this terrain and at this altitude the small, widely spaced patches of slim-leaved snow tussock are important as are any small wet areas with their diverse cushion plants and turfs.

COMMENT ON THE PROPOSED CHAIRLIFT LINE

If the proposal is approved then the siting of the lift towers and base station will be important for reducing or eliminating damage to the very sparse vegetation. Because the vegetation is so spread out it should be relatively simple to site the towers on rocky areas devoid of plant life. If this is carried out then there the impact on the ecology will be negligible or extremely small.

TRACKS

It is not proposed to create tracks for access to build the lift towers. Tracks would add considerably to the visual impact and increase the risk of damage to the sparse ecology.

REFERENCES

- de Lange, P.J.; Norton, D.A.; Courtney, S.P.; Heenan, P.B.; Barkla, J.W.; Cameron, E.K.; Hitchmough, R.; Townsend, A.J. 2009: Threatened and uncommon plants of New Zealand (2008 revision). *New Zealand Journal of Botany* 47: 61-96

Appendix 3: Engineering Drawings

ORIGINAL RETURN TERMINAL FOOTING

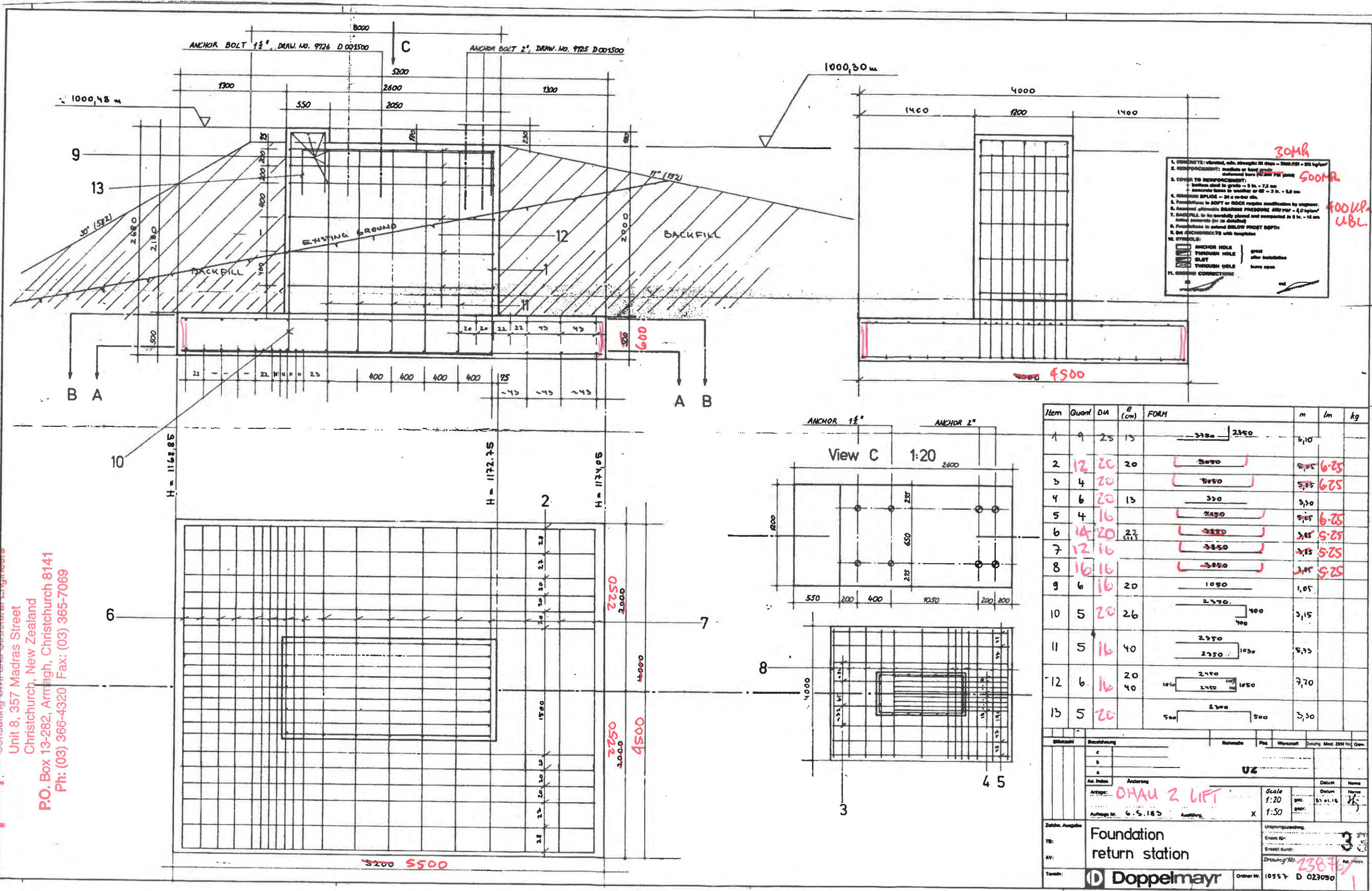

LEWIS & BARROW LTD
 Consulting Civil and Structural Engineers
 Unit 8, 357 Madras Street
 Christchurch, New Zealand
 P.O. Box 13-282, Armagh, Christchurch 8141
 Ph: (03) 366-4320 Fax: (03) 365-7069

An. Index: **OHANU 2 LIFT**
 Scale: 1:20
 Datum: 15.11.16
 Name: **JK**
 An. Index: 6.5.183
 Drawing No: **23876**
 Order No: 10557 D 027050
D Doppelmayr

tower angle

Anchor bolts 2" x 60"
 Drawing No. 924 D 001500
 9725 D 001500

backfill to be 200mm
 below CTF.
 CTF vertical, horizontal
 (see schedule or profile)

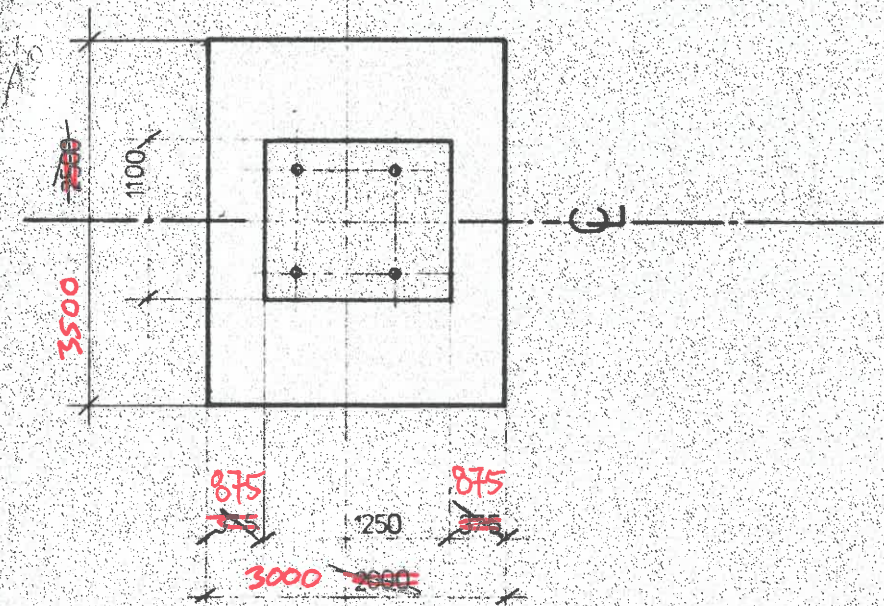
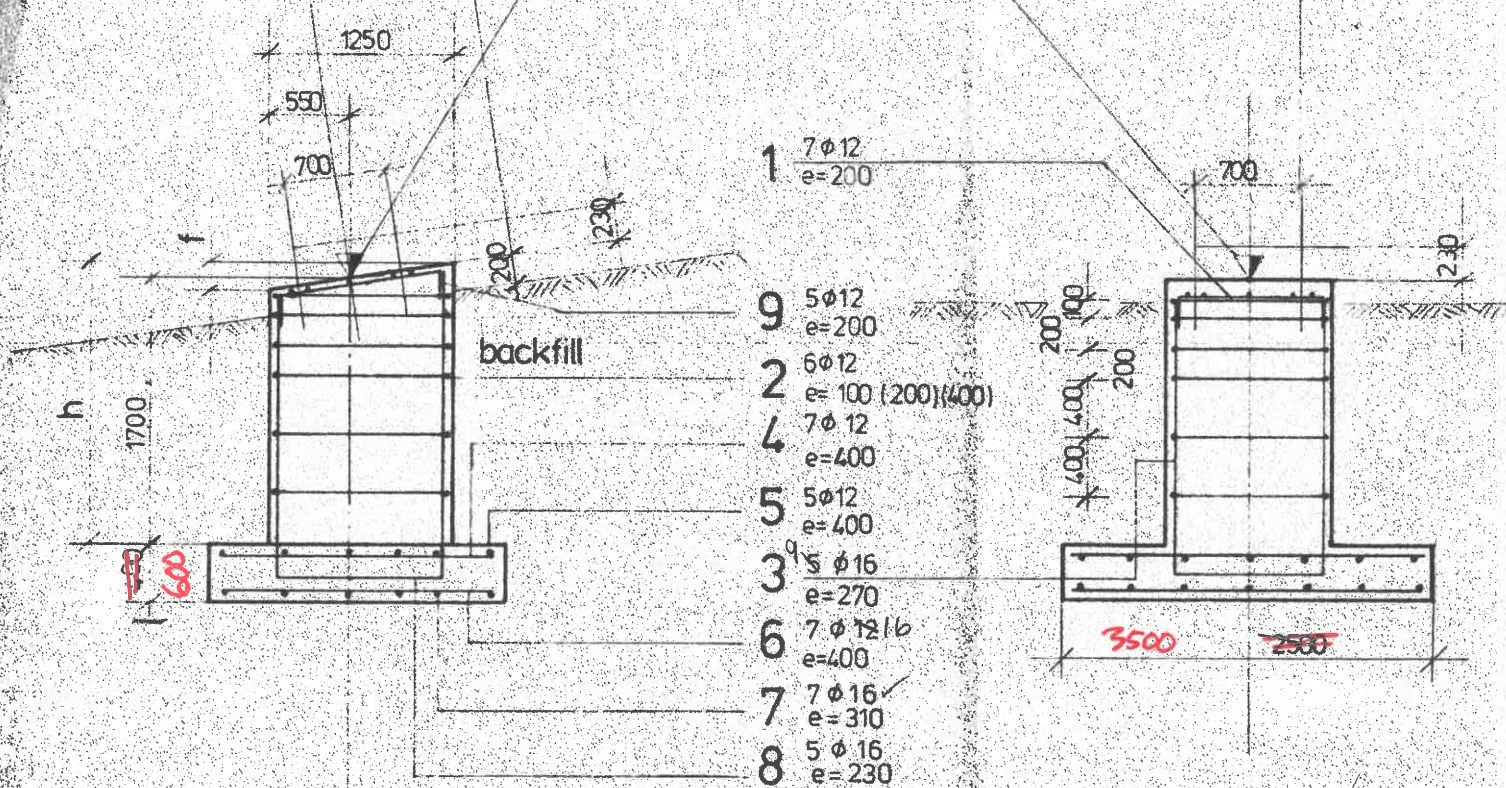

$V = 8.65 \text{ m}^3$

Tower	h (mm)	f (mm)
0°	1700	0
5°	1760	110
10°	1820	220
15°	1890	330

ITEM	QUANT.	DIA	e(mm)	FORM	m	lm	kg	
1	5	H 216	200	220 1070 220	1.51	7.6	68	
2	6	H 216	100 (200) (400)	950 1100 100 1100 950	4.30	25.8	23.0	
3	9/6	H 1620	270	1820 920 1820	4.56	22.8	36.0	
4	12/8	H 216	400	1650 3750	1.85	13.0	11.5	
5	10/5	H 216	400	2350 9250	2.35	11.8	10.5	
6	12/8	H 216	400	1650 3750	1.85	13.0	11.5	
7	10/8	H 16	310	2350 9250	2.35	16.5	26.0	
8	9/6	H 1620	230	1820 1070 1820	4.71	23.6	37.2	
9	5	H 216	200	220 920 220	1.36	6.8	6.1	
							$\Sigma 168.6$	

Tower	horizontal	vertical	CTF	tower angle
1	71.43	1690.35		15°
2	136.78	1720.28		15°
3	176.33	1734.32		15°
4	234.04	1774.53		15°
6	375.97	1857.87		15°
8	522.62	1925.10		15°
9	569.14	1951.26		10°

- CONCRETE: vibrated, min. strength: 28 days - 3000 PSI - 225 kg/cm²
- REINFORCEMENT: medium or hard grade deformed bars (40,000 PSI yield) 30 MPa 500 MPa
- COVER TO REINFORCEMENT:
 - bottom steel to grade - 3 in. - 7.5 cm
 - concrete faces to weather or fill - 2 in. - 5.0 cm
- MINIMUM SPLICE - 24 x re-bar dia.
- Foundations in SOFT or ROCK require modification by engineer.
- Assumed allowable BEARING PRESSURE 4000 PSI - 2 kg/cm² 4000 PSI 2 kg/cm²
- BACKFILL to be carefully placed and compacted to 3 in. - 20 cm below concrete (or as detailed)
- Foundations to extend BELOW FROST DEPTH
- Set ANCHOR BOLTS with templates
- SYMBOLS:
 - ANCHOR HOLE
 - THROUGH HOLE
 - SLOT
 - THROUGH HOLE
 grout after installation
leave open
- GROUND CORRECTIONS

Lift name: "OAAU 2 LIFT"
 N.Z.
 G.S. 183

Scale: 1:50

drawn: [signature]
 appr: [signature]

Date: 29/1/19
 Name: [signature]

Foundation Type 20"

Tower No. 1, 2, 3, 4, 6, 8, 9

Doppelmayr ED. 70.

Drawing No. 23876/2
 S-37.825-1

34

LEWIS & BARROW LTD
 Consulting Civil and Structural Engineers
 Unit 8, 357 Madras Street
 Christchurch, New Zealand
 P.O. Box 13-282, Armagh, Christchurch 8141
 Ph: (03) 366-4320 Fax: (03) 365-7069

Tower angle

Anchor bolts 2" x 60"
 Drawing No. 924 D 001500
 9725 D 001500

backfill to be 200mm
 below CTF

CTF vertical, horizontal
 (see schedule or profile)

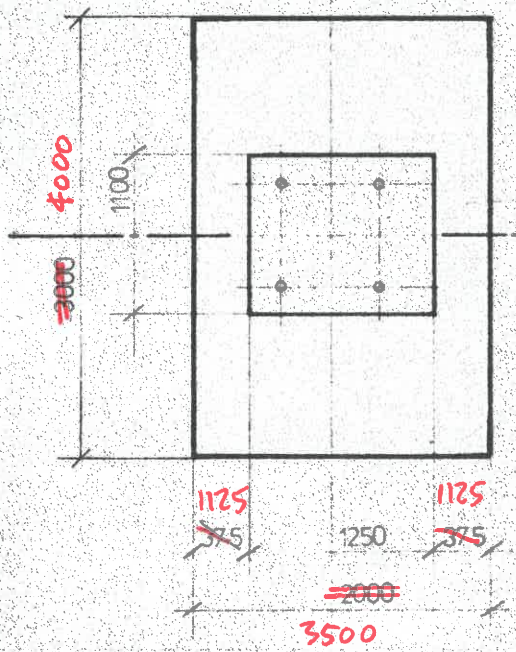
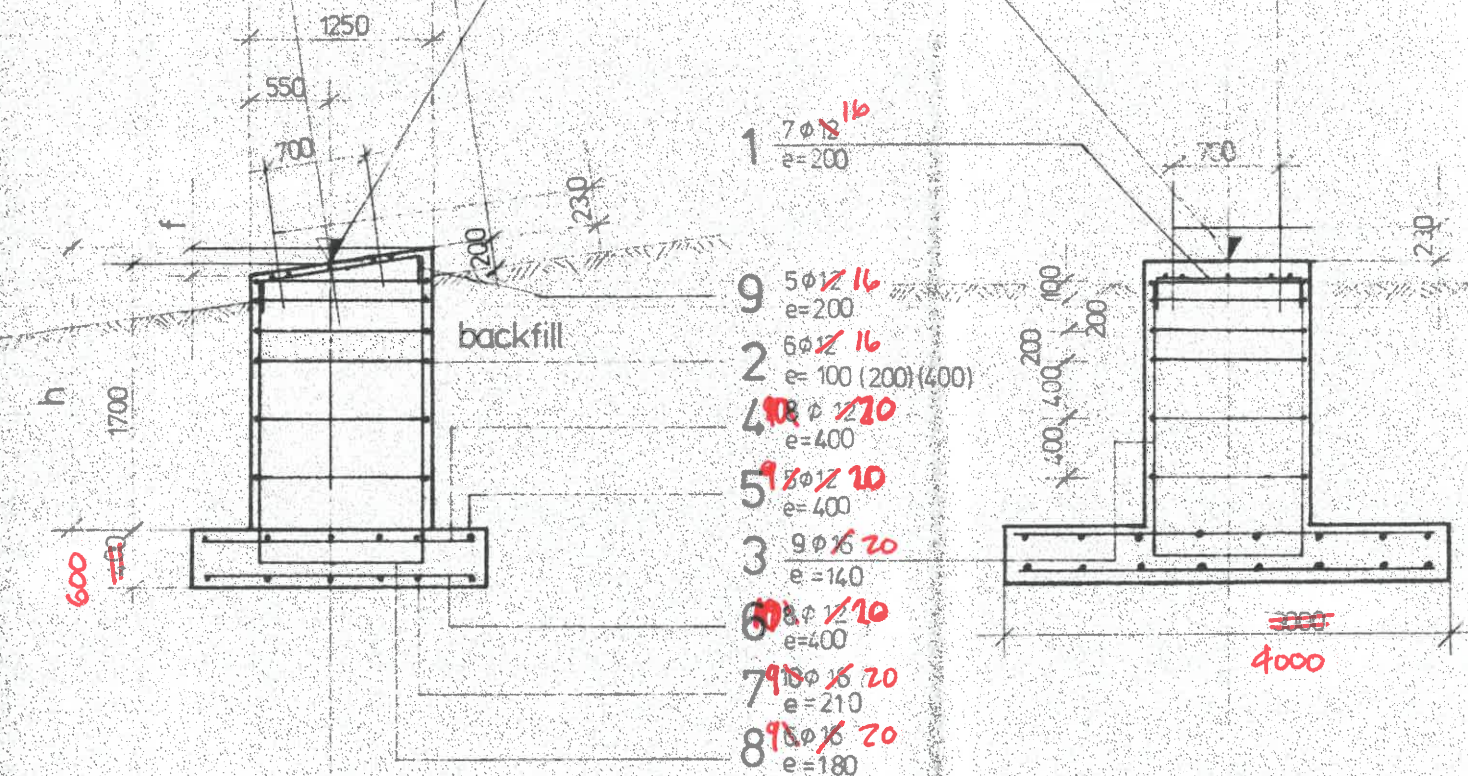

- 1 7φ16
e=200
- 2 6φ16
e=100 (200) (400)
- 3 9φ20
e=140
- 4 10φ20
e=400
- 5 9φ20
e=400
- 6 8φ20
e=400
- 7 9φ20
e=210
- 8 9φ20
e=180
- 9 5φ16
e=200

$V = 10.75 \text{ m}^3$

Tower	h (mm)	f (mm)
0°	1700	0
5°	1760	110
10°	1820	220
15°	1890	330

ITEM	QUANT	DIA	e (mm)	FORMO	m	lm	kg
1	5	H 20	200	220 1070 220	151	7.6	68
2	6	H 20	100 (200) (400)	950 1100 100 950 1100	4.30	25.8	23.0
3	9	H 20	140	1820 920 1820	4.56	41	64.8
4	10	H 20	400	1850 4250	1.85	14.8	13.2
5	9	H 20	400	2850 4750	2.85	14.3	12.7
6	10	H 20	400	1850 4150	1.85	14.8	13.2
7	9	H 20	210	2850 4750	2.85	28.5	45
8	9	H 20	180	1820 1070 1820	4.71	28.3	44.7
9	5	H 20	200	220 920 220	1.36	6.8	6.1
					Σ = 229.5		

Tower	horizontal	vertical	Tower angle
5	310.54m	181.404m	15°

1. CONCRETE: vibrated, min. strength: 28 days - 3608 PSI - 251 kg/cm²
2. REINFORCEMENT: medium or hard grade 3C MPa deformed bars (40000 PSI yield) 500MPa.
3. COVER TO REINFORCEMENT:
 - bottom steel to grade - 3 in. - 7.5 cm
 - concrete faces to weather or fill - 2 in. - 5.0 cm
4. MINIMUM SPLICE - 24 x re-bar dia.
5. Foundations in SOFT or ROCK require modification by engineer.
6. Assumed ~~allowable~~ BEARING PRESSURE ~~4225 kPa~~ 40000 kPa UBC
7. BACKFILL to be carefully placed and compacted to 3 in. - 20 cm below concrete (or as detailed)
8. Foundations to extend BELOW FROST DEPTH
9. Set ANCHORBOLTS with templates
10. SYMBOLS:
 - ANCHOR HOLE
 - THROUGH HOLE
 - SLOT
 - THROUGH HOLE
11. GROUND CORRECTIONS

c			
b			
e			
Lift name: CHAU 2 LIFT NZ		Scale: 1:50	Date: 24/1/12

Foundation Type 20"
 Tower No. 5

36

Drawing No. 23876/3
 S-37.825-3

Doppelmayr ED. 70

LEWIS & BARROW LTD
 Consulting Civil and Structural Engineers
 Unit 8, 357 Madras Street
 Christchurch, New Zealand
 P.O. Box 13-282, Armagh, Christchurch 8141
 Ph: (03) 366-4320, Fax: (03) 365-7069

ORIGINAL 24" Ø PIPE TOWER FOOTING

TOWER ANGLE

backfill to be 200 (mm) below CTF

CTF vertical, horizontal

Anchor bolts 2"x60"
 Drawing No
 924 D 001500
 9725 D 001500

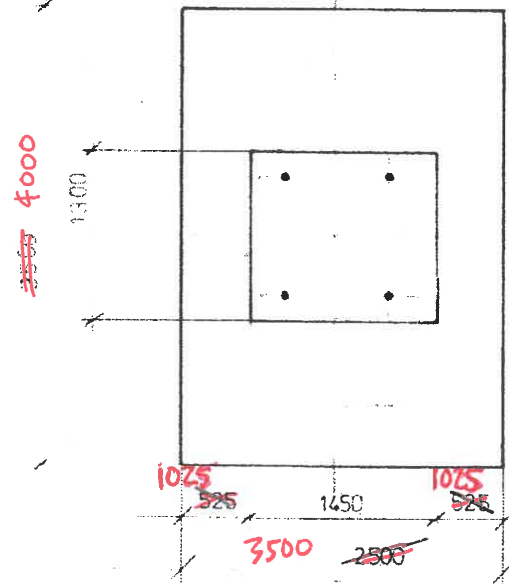
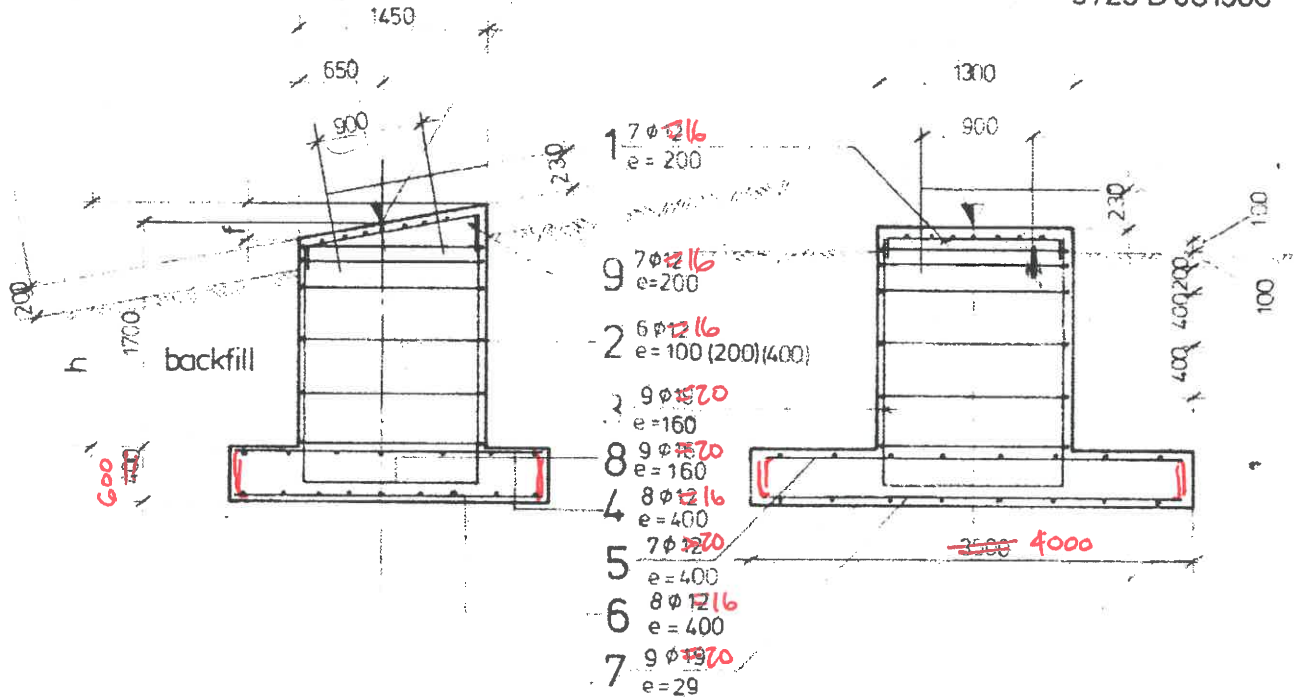

$V = 11.60 \text{ m}^3$

Tower	h (mm)	f (mm)
0°	1700	0
5°	1770	130
10°	1840	260
15°	1910	390

ITEM	QUAN	DIA	e	FORM	m	lm	kg
1	7	H 216	200	220 1270 220	1.71	11.97	10.7
2	8	H 216	100 (200) (400)	1150 1300 1300 1150	5.10	30.6	27.2
3	9	H 270	16	1820 1120 1820	4.76	42.8	95.5
4	8	H 216	400	4250 2350	2.35	18.8	16.7
5	9	H 270	400	4750 3350	3.35	23.5	20.9
6	8	H 216	400	4250 2350	2.35	18.8	16.7
7	9	H 270	29	4750 3350	3.35	30.2	67.4
8	9	H 270	9	1820 1270 1820	4.91	44.2	69.8
9	7	H 216	200	220 1120 220	1.56	10.92	9.7
					Σ 334.6		

Tower	horizontal	vertical CTF	Tower angle	Notes
7	456.07m	1890.34	15°	1. CONCRETE: vibrated, min. strength: 28 days - 3000 PSI - 225 kg/cm ³ 2. REINFORCEMENT: medium or hard grade deformed bars 40000 PSI yield 500 MPa 3. COVER TO REINFORCEMENT: - bottom steel to grade - 3 in. - 7.5 cm - concrete faces to weather or fill - 2 in. 5.0 cm 4. MINIMUM SPLICE - 24 x re-bar dia. 5. Foundations in SOFT or ROCK require modification by engineer. 6. Assumed allowable BEARING PRESSURE 4000 PSI 25 kg/cm ² 7. BACKFILL to be carefully placed and compacted to 8 in. 20 cm below concrete (or as detailed) 8. Foundations to extend BELOW FROST DEPTH 9. Set ANCHOR BOLTS with templates 10. SYMBOLS: [Symbol] ANCHOR HOLE grout after installation [Symbol] THROUGH HOLE leave open [Symbol] SLOT [Symbol] THROUGH HOLE 11. GROUND CORRECTIONS [Symbol] fill [Symbol] cut

LIFT NAME	Scale	Date	Name
OHAU 2 LIFT NZ	1:50	29/1/19	CJG

Foundation Type **24"**
 Tower No: **7**
 Drawing No **23876/4**
S-37.825-5
Doppelmayr ED.70.

ORIGINAL DRIVE TERMINAL FOOTINGS

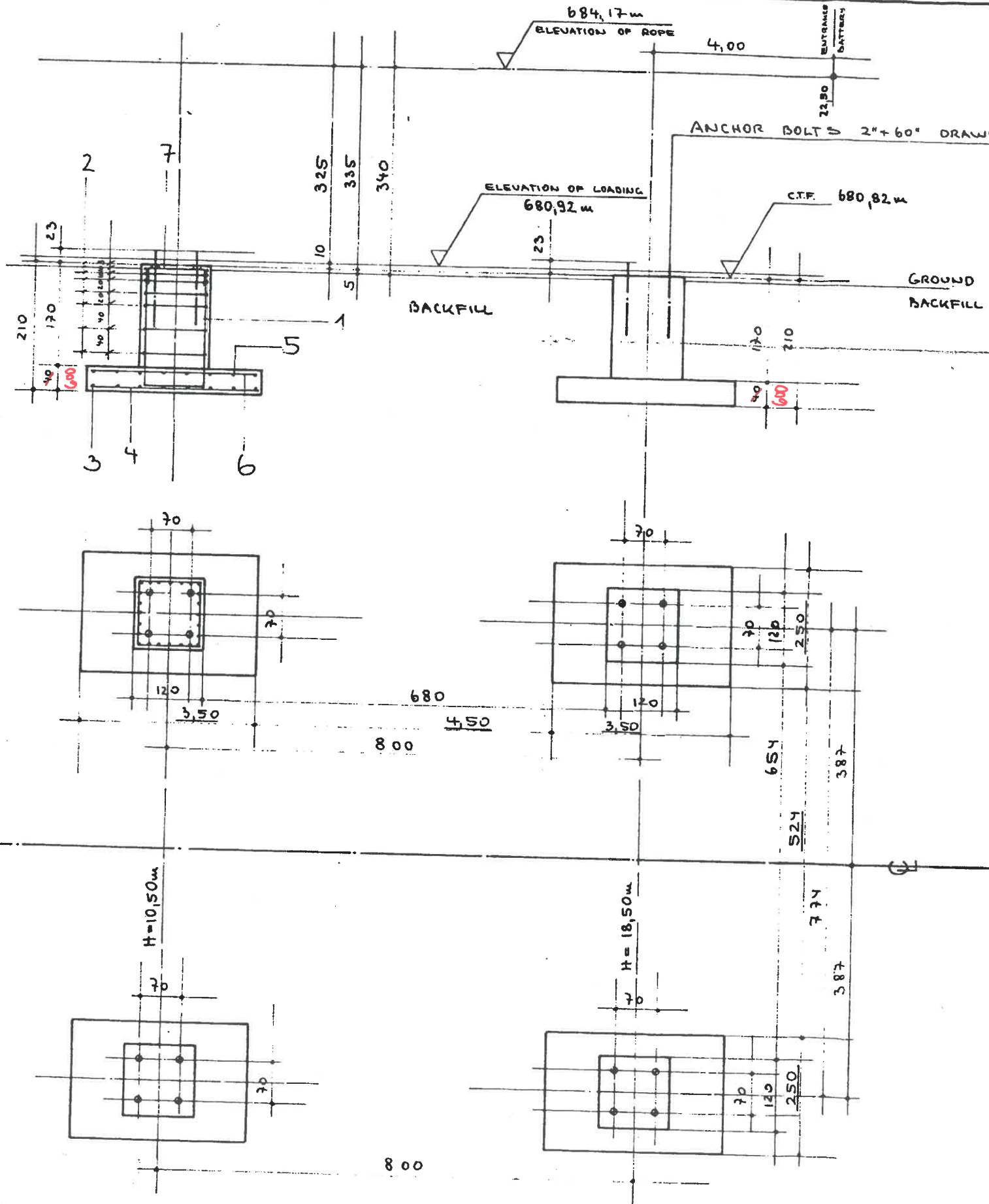

25 MPa

500 MPa

400 MPa

UBC

1. CONCRETE: vibrated, min. strength: 28 days - 25 MPa
2. REINFORCEMENT: medium or hard grade deformed bars (500 MPa yield)
3. COVER TO REINFORCEMENT:
 - bottom slab to grade - 3 in. - 7,5 cm
 - concrete faces to weather or fire - 2 in. - 5,0 cm
4. MINIMUM SPLICE - 24 x re-bar dia.
5. Foundations in SOFT or ROCK require modification by engineer.
6. Assumed ultimate BEARING PRESSURE 3000 PSF - 1,5 kg/cm²
7. BACKFILL to be carefully placed and compacted to 6 in. - 15 cm below concrete (or as detailed)
8. Foundations to extend BELOW FROST DEPTH
9. Set ANCHOR BOLTS with templates
10. SYMBOLS:

	ANCHOR HOLE	grout after installation
	THROUGH HOLE	leave open
	SLOT	
	THROUGH HOLE	
11. GROUND CORRECTIONS

ITEM	QUANT.	DIA	e (mm)	FORM	m	Run	kg
1	12	H20	17		4,82		
2	7	H16	5 10 20 40		4,40		
3	9	H20	42		2,35	3250	2,35
4	6	H20	47		3,35	4250	3,35
5	9	H16	42		2,35	3250	2,35
6	6	H16	47		3,35	4250	3,35
7	8	H16	10		1,62		

Stückzahl	Bezeichnung	Rohmaße	Pos	Werkstoff	Zeichn. Mod. DIN Nr.	Gew.
c						
b						
a						
Ae. Index	Änderung				Datum	Name
Anlage: OHAN 2 LIFT				Maßstab	gez.	Datum
Auftrags Nr. 6-5-183				Ausführg.	gepr.	
				X	29/1/19	CSL
Zeichn. Ausgabe	Foundation drive station		Ursprungszeichnung.		Ersatz für: 32	
TB:			Ersetzt durch:		Zeichnung Nr. 23876/5 Re. Index	
AV:			Termin:		Ordnernr 10560 D 217000 A	
D Doppelmaur						



Unit 8, 357 Madras Street
Christchurch, New Zealand
P.O. Box 13-282
Armagh, Christchurch 8141
Telephone (03) 366-4320
Email eng@lewisandbarrow.co.nz
www.lewisandbarrow.co.nz

Ohau Ski Field Passenger Lift 2

File:23876

Engineering Specification Notes

1. All work shall comply with the relevant clauses of the N.Z. Building Code.
2. Batter all excavations to a safe and stable angle. A minimum of 1 horizontal to 2 vertical is suggested as an initial minimum but will be dependant on the loosening and density of the insitu material. Safe and stable access for personal working in the excavation base is required.
3. All site won insitu excavated material is to be safely and securely stored on site for replacement and compaction over the base pad upon completion of the foundations. Measures to ensure downhill sliding of excavated material is prevented during the lift construction period are required to ensure safe working conditions at all times.
4. All foundation concrete shall have a minimum compressive strength of 30MPa at 28 days. Provide air entraining admixture to the range 4% to 8% in accordance with NZS 3112:Part 1. Normal water reducing agents and super plasticisers may be used but the Engineer shall be notified for approval of any proposed additive to be used.
5. All concrete shall be constructed in accordance with the requirements of NZS 3101.
6. Foundation depths shown are a minimum only. All foundations shall extend down to solid bearing. A UBC of 400kPa is assumed and is to be site verified for all foundation locations.
7. Should unexpected or variable ground conditions be encountered on the site, the Engineer shall be consulted for additional foundation details.
8. Hardfill for backfilling over base pads is to be site won material placed and compacted in maximum 200mm lifts to 95% MDD.
9. All concrete shall be thoroughly vibrated with mechanical vibrators when placed.
10. Where designated D, reinforcement shall be deformed bars, where designated R reinforcement shall be plain bars, both being grade 300E complying with AS/NZS 4671:2001. Where designated H, reinforcement shall be deformed bars of grade 500E MA complying with AS/NZS 4671:2001. All reinforcement to be manufactured by Pacific Steel NZ.
11. All vertical starter bars shall extend into the foundations with a hook as shown.
12. Where laps are not shown, they shall be 45 diameters for D bars and 75 diameters for H bars.
13. The contractor shall develop a considered site-specific safety plan to mitigate site safety risks during construction.
14. All details on this plan take precedence to all other plans and specifications.
15. The Engineer shall be engaged by the Owner to inspect and approve a sample of the foundation excavations and reinforcement prior to pouring concrete. The first foundation is required to be inspected as a minimum. Photos are to be provided of all other excavation locations and all reinforcement cages prior to pouring of any concrete.

Bibliography

de Lange, P., & et al. (2017). *Conservation Status of New Zealand indigenous vascular plants, 2017*. Department of Conservation.

Espie, P., & et al. (1984). *Mackenzie Ecological Region: NZ Protected Natural Area Programme*. Wellington: Department of Lands and Survey.

Nelson, D., & Nunn, J. (2008, March 31). Email: Ohau Snowfields invertebrate site.

NZ Plant Conservation Network. (n.d.). NZPCN website. New Zealand.

NZFS. (1986). *Ohau Forests Draft Management Plan 1985-95*.

Simpson, N. (2012). *Ohau Snowfields: Ecological Report on the proposed new chairlift in the upper basin*.

Young, R. (2008, October 5). File Note: Ohau Ski Area Visit 5/10/08.